

SONY



**An overview
to the technology
behind MiniDisc.**

Copyrights © Sony Corporation
All rights reserved. No part of this manual may be
reproduced in any form, or by any means, without
permission in writing from the publisher.

Sony Corporation
Audio Development Group
1-7-4 Konan, Minato-ku
Tokyo 108 Japan



Table of Contents

<i>Why Sony Created the MiniDisc</i>	2
<i>The MiniDisc System</i>	
Format Overview	4
Shock-Resistant Memory	6
Random Access Functioning	8
Signal Recording Format	10
<i>MiniDisc Technology Highlights</i>	
Recordable & Playback-only MiniDiscs ...	12
MD Pickup	14
ATRAC Data Compression	16
Magneto-Optical Recording	20
<i>MiniDisc Technology Closeups</i>	
Magnetic Field Modulation System	22
MiniDisc Mastering Systems	26
<i>Glossary of MiniDisc Terminology</i>	28

Why Sony Created the MiniDisc

In the creation of the MiniDisc, every need of those who enjoy music has been taken into account. MiniDisc enables digital quality playback and recording. Since it is a disc, it allows quick random access just like CD. MiniDisc is also extremely compact for portable convenience, and is designed to resist the effects of shock and movement. The crystallization of advanced technology in a broad variety of fields, MiniDisc offers the ultimate in versatility, sound quality, and convenience. The portable digital recording format of the future is now a reality.

Durable, long-lasting sound media

Media such as books, photographs, and recordings are more than just a form of entertainment. They represent a record of the times, and are an important part of our cultural legacy. With this in mind, Sony created the MiniDisc to be a durable and highly reliable sound recording format, virtually unaffected by external magnetic fields, and that retains its inherent quality despite repeated recording and playback. MiniDisc has been engineered to stand the test of time, and will no doubt bring the music and voices of our era to future generations.

The Recordable Optical Disc

It was in 1970 that Sony first recognized the potential of optical disc, and began a program of research and development with the goal of creating a product with non-contact recording and playback capability, extremely long medium life, high-speed random access, and low recording cost. The results of this research has been seen over the years in the form of several Sony high-performance optical disc products, including video disc, CD, and CD-ROM. In the late 1970's, Sony began research on an optical disc product that could be recorded in the same way as magnetic tape. In 1988, Sony introduced a rewritable magneto-optical disk for computer data storage.

The Semiconductor Laser

An essential part of optical disc technology, the semiconductor laser was recognized early by Sony for its remarkable future possibilities. Sony has aggressively researched the role of electronic technology in the application of semiconductor lasers to optical disc systems. Sony's development efforts have centered on compactness, long service life, high reliability, and low production cost. Advances in these areas have served to optimize optical disc advantages, such as non-contact operation and fast access, and have made possible Sony's ultra-thin portable CD players.

Future applications limited only by the imagination

As technology advances at an increasingly rapid pace, many new developments run the risk of becoming obsolete before their time. In information recording, an emerging trend is the integration of sound, images, alphanumeric data, and other information. Thus, the development of new audio media must take multi-media integration and interaction into account. MiniDisc's quick random access and other performance features, which are not possible with tape formats, assure excellent operability for audio use, while also playing a positive role in future multi-media trends. Within this context, Sony believes that the era of tape as an audio medium will eventually come to an end.

A broad spectrum of state-of-the-art Sony technology

New technology for consumer products must be refinements which are adaptable to mass production. MiniDisc is based on a broad spectrum of technologies which have already been proven successful. Since pre-recorded MiniDiscs are produced much like universally accepted Compact Discs, mass production requires only minor modifications to existing manufacturing facilities. Moreover, recordable MiniDiscs are based on magneto-optical technology, which is becoming increasingly popular in computer applications. Although MiniDisc is state-of-the-art, it is based on developments which have already shown commercial viability.

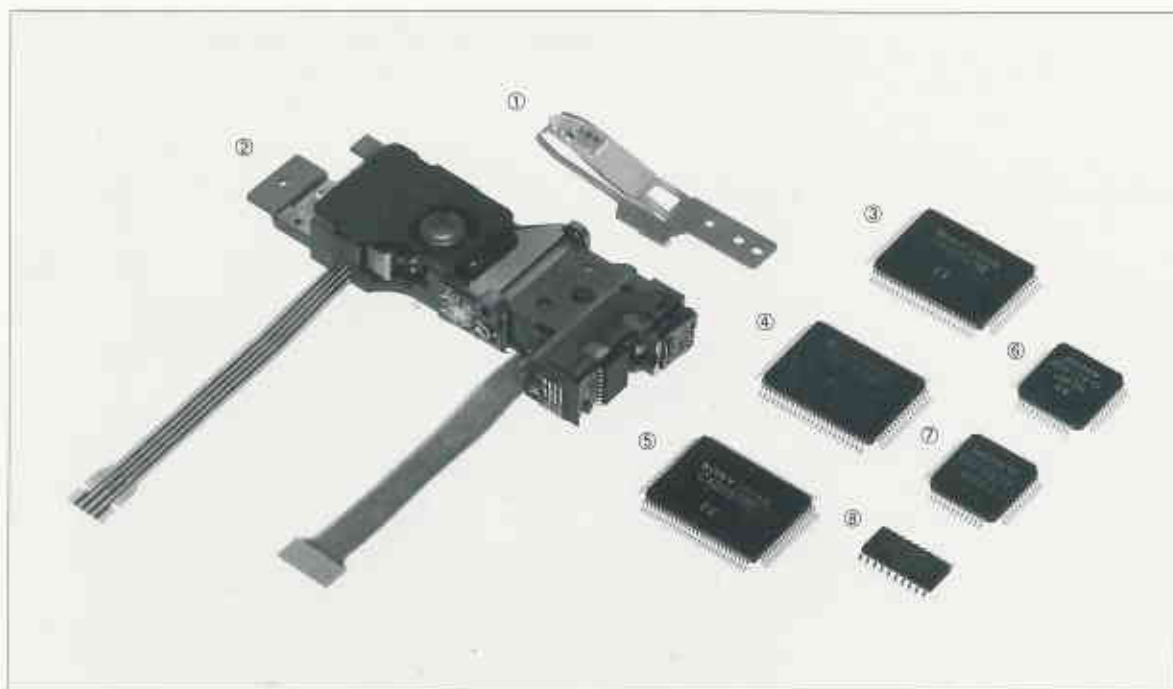

These specialized LSI and key components have been developed specifically for MiniDisc applications:

- | | |
|---|---|
| ① RF320-74 Magnetic Field Modulation Recording Head | ⑤ CXD2527R ATRAC Encoder/Decoder |
| ② KMS-130A MiniDisc Record/Playback Pickup | ⑥ CXA1381Q RF Matrix Amplifier |
| ③ CXD2525Q/R EFM/ACIRC Encoder/Decoder | ⑦ CXA1082BQ Servo Signal Processing LSI |
| ④ CXD2526Q Shock-Resistant Memory Controller | ⑧ CXA1380M ADIP Demodulator |

Format Overview

MiniDisc at a Glance

1. It allows fast random access, just like CD.
2. It's a 64 mm disc housed in a rigid protective cartridge, much like a computer disc.
3. It's available in two types:
 - Playback-only MiniDiscs for pre-recorded music, sold only by record companies.
 - Recordable MiniDiscs for home recording and playback, sold by tape and media manufacturers.
4. It can contain 74 minutes (the same as a CD) of high quality digital sound, thanks to advanced data compression technology.
5. It is highly resistant to shock during playback, thanks to a semiconductor memory and efficient data compression.

Two Types of MiniDiscs

Playback-only MiniDiscs have been designed for pre-recorded music sold by record companies. Manufactured using the same process as CDs, playback-only MiniDiscs feature full-cover artwork. Since they cannot be recorded, it is impossible to inadvertently "record over" the music recorded on them.

Recordable MiniDiscs are magneto-optical discs which make use of new magnetic-field modulation technology to enable recording by the user. A key feature of this technology is that it allows the recordable MiniDisc to be re-recorded a virtually unlimited number of times. Once recorded, however, the life of the sound data is the same as that of CD, thanks to a direct overwriting technology breakthrough achieved by Sony in 1989. This system performs recording through the use of a laser beam focused on one spot on the disc, and a magnetic field applied on the corresponding spot on the other side. Only through this combination of laser light and a magnetic field can the recordable MiniDisc be recorded or re-recorded. Thus, the recorded sound signal is virtually permanent.

Same Modulation System and Error Correction Code as CD for recording signals is another prime feature of MiniDisc, as shown in Table 1. Innovative new additions to the MiniDisc format include data compression encoding/decoding, and a magnetic recording head for recordable MiniDiscs.

Block Diagram of the MiniDisc System

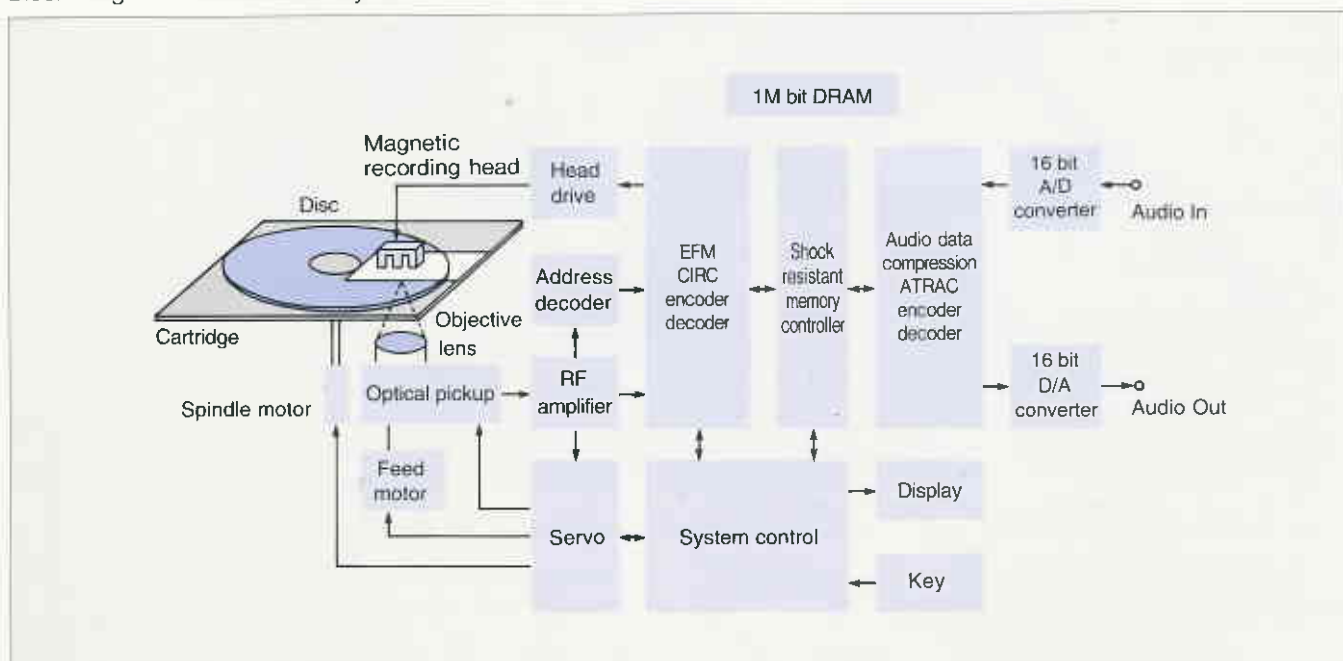



MiniDisc playback-only type (left) and recordable MD (right).

Table 1. MiniDisc Specifications

<ul style="list-style-type: none"> ● Major specifications 		<ul style="list-style-type: none"> ● Audio characteristics 	
Recording/ playback time	74 minutes	Channels	2 channels (stereo/monaural)
Cartridge size (WHD)	72 x 68 x 5mm	Frequency range	5 – 20,000Hz
<ul style="list-style-type: none"> ● Disc specifications 		Dynamic range	105dB
Diameter	64mm	Wow and flutter	Unmeasurable
Thickness	1.2mm	<ul style="list-style-type: none"> ● Signal format 	
Diameter (Center hole)	11mm	Sampling frequency	44.1kHz
Diameter (Beginning of program)	32mm	Compression system	ATRAC ^{*1}
Diameter (Beginning of lead-in)	29mm	Modulation system	EFM ^{*2}
Track pitch	1.6 microns	Error correction system	CIRC ^{*3}
Linear velocity	1.2 – 1.4meters/sec. (CLV)	<ul style="list-style-type: none"> ● Optical parameters 	
		Laser wavelength	Standard 780nm
		Laser diameter	Standard 0.45
		Recording power	5mW(max.)
		Recording system	Magnetic Field Modulation

^{*1} Adaptive Transform Acoustic Coding

^{*2} Eight-to-Fourteen Modulation

^{*3} Cross Interleave Reed-Solomon Code

Shock-Resistant Memory

The biggest problem in using optical discs in portable applications has been that of skipping due to shock or vibration. Fortunately, this problem has been dramatically minimized in the MiniDisc system through the adoption of a high-capacity 1 Mbit semiconductor memory. The layout of this memory system is illustrated in Fig. 1.

Digital Data Storage

The memory acts as a buffer, holding digital data equivalent to about three seconds of playing time before it is sent for conversion into analog signals for playback. If the player is exposed to shock or sudden movement, which jars the pickup from its position on the disc, the semiconductor memory will continue to output digital data to maintain playback. Since the memory itself is a solid-state device, it is unaffected by shock or movement. Since the position of the laser pickup is constantly monitored using address locations which are integral to both recordable and pre-recorded MiniDiscs, it can quickly resume position.

Data Compression Utilized

One method to achieve efficient operation of the shock-resistant memory is to use digital data compression. While the pickup reads data from the disc at the rate of 1.4 Mbit/second, playback requires a rate of only 0.3 Mbit/second. This is possible through the use of ATRAC (Adaptive Transform Acoustic Coding), an advanced data compression technology that enables high quality digital sound reproduction using only about 1/5th of the amount of data normally required. If the pickup loses its position, and the flow of data into the 1 Mbit memory is interrupted, data will continue to flow out of the memory at the rate of 0.3 Mbit/second to enable playback to continue for about three seconds. Once the laser pickup resumes its original position, however, it will read data from the disc at the rate of 1.4 Mbit/second, and thus replenish the data in the memory in less than a second.

Fig. 1 Shock-resistant Memory

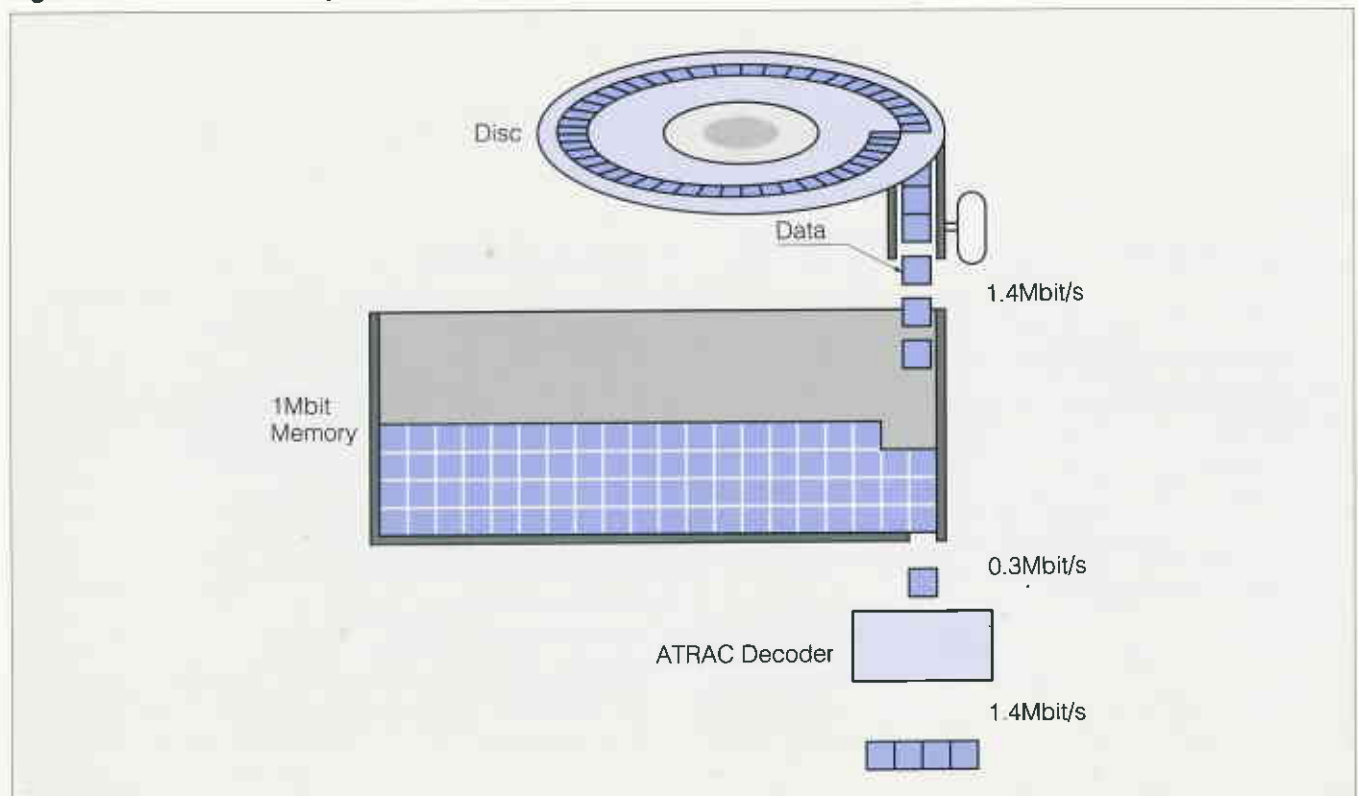

Reading Signals in Intervals

During normal operation, signals are read from the disc in intervals because the data pickup rate is about five times faster than is required for playback. This differs from CD playback, which is always at a constant 1.4 Mbit/second rate since data compression is not used. Fig. 2 illustrates how the MiniDisc system reads data from the disc in intervals, while ATRAC decoding reorients the data on the time-axis before D/A conversion. CD play-

back, on the other hand, requires a constant readout of the signals. In the presence of shock or movement, however, the signal flow is interrupted, and once normal data pickup resumes, the amount of information read in the subsequent interval is increased to cover the time lost when the pickup was out of position. Once the contents of the memory are replenished, however, the pickup resumes reading the signals at regular intervals.

Fig. 2 Reading Signals in Intervals

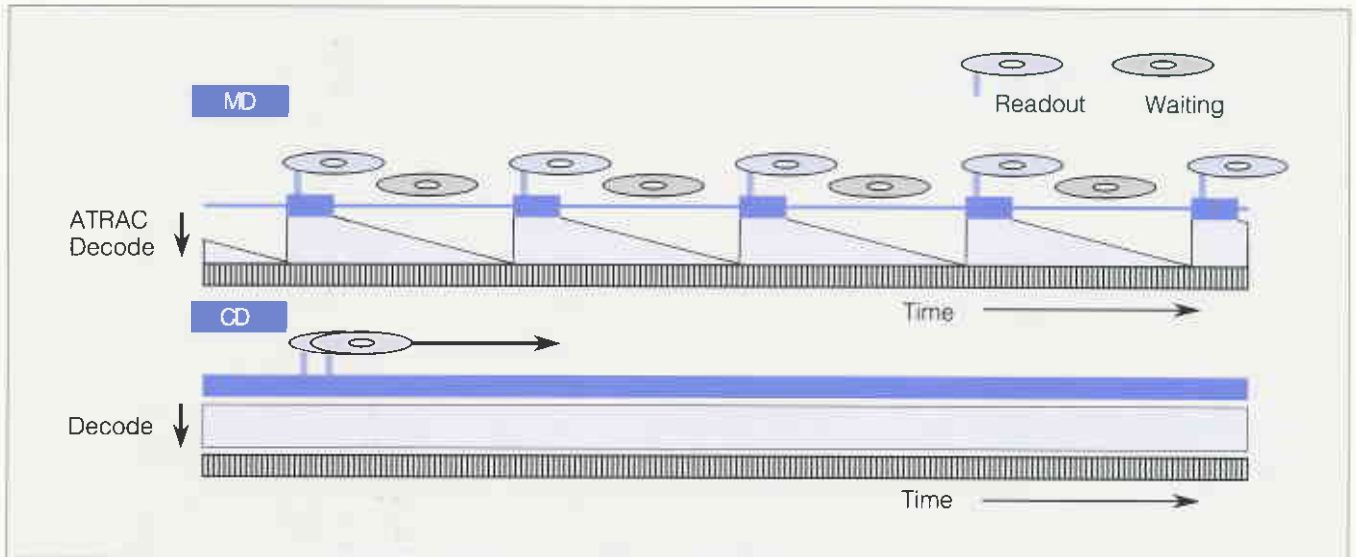
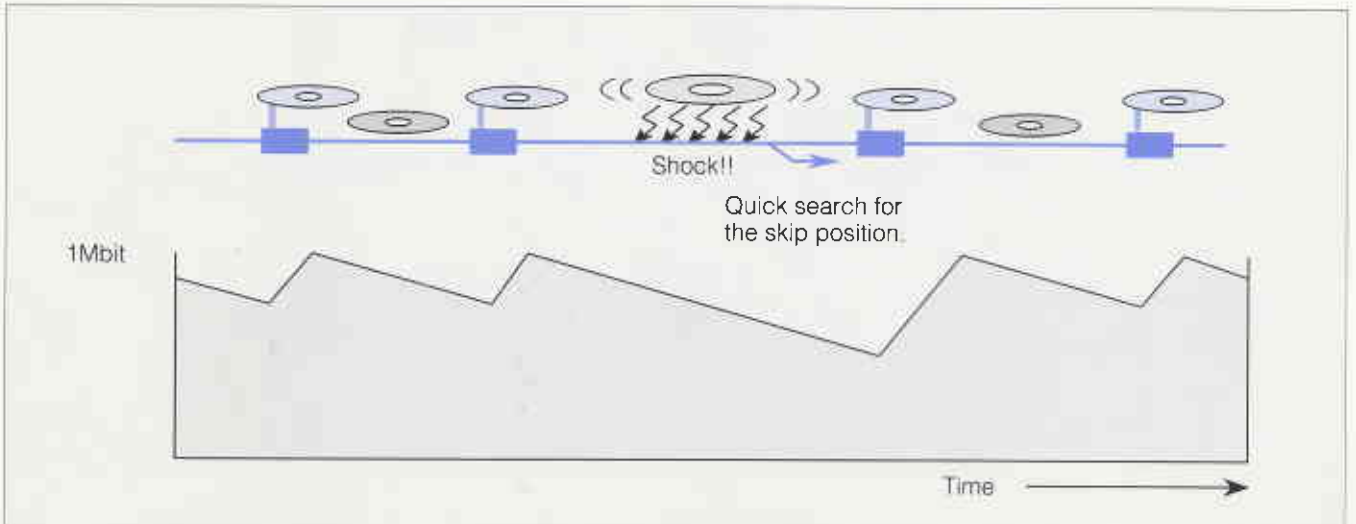

Fig. 3 Interval Reading During Shock or Movement



Random Access Functioning

The MiniDisc format has been designed for complete random access functioning, which is its most important feature. Playback-only MiniDiscs are recorded like CDs, and have addresses for each selection which enable quick random access. Recordable MiniDiscs, on the other hand, have special "pre-grooves" which allow quick and easy access to any point on the disc. In addition, recordable MiniDiscs also contain a user table-of-contents (UTOC) area, allowing the tracks to be renumbered in any order in a matter of seconds.

Only in a Disc Format

Only disc formats are able to offer high-speed random access, which is just not possible with tape formats. The advent of the CD player has changed our expectations of cueing time. By comparison, cueing time for a conventional analog cassette (which can be as long as one minute) now seems too long, and does not impart the feeling of modern technology. On the other hand, MiniDisc enables quick random access just like CD, in both the playback-only and recordable versions.

Pre-grooves for Quick Access

Recordable MiniDiscs are equipped with special pre-grooves which cover the entire disc recording area. These pre-grooves enable tracking and spindle servo control during both recording and playback. As Fig. 4 illustrates, these pre-grooves are shifted very slightly to create addresses in 13.3 millisecond (ms) intervals, which allow very stable high-speed random access.

User Table of Contents (UTOC)

Track number addresses (start and finish) are recorded in a UTOC area on the inner circumference of the disc, which is similar to a floppy disc directory. This enables track number editing in seconds, rather than having to wait for the actual performance time to rewrite a track address as is required in time division systems. Fig. 5 shows the changes that occur in UTOC after two common track-editing operations — eliminating an unwanted track and combining two tracks into one.

Fig. 4 Pre-grooves on a Recordable MiniDisc

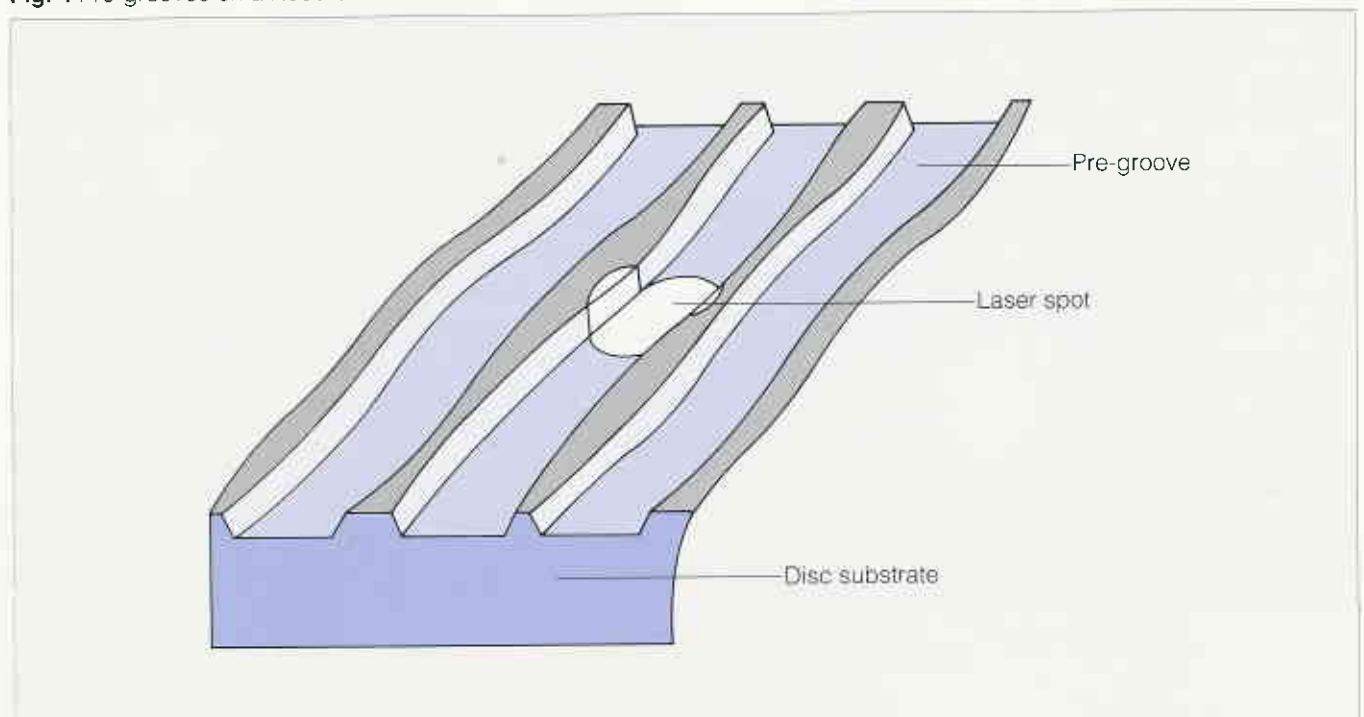
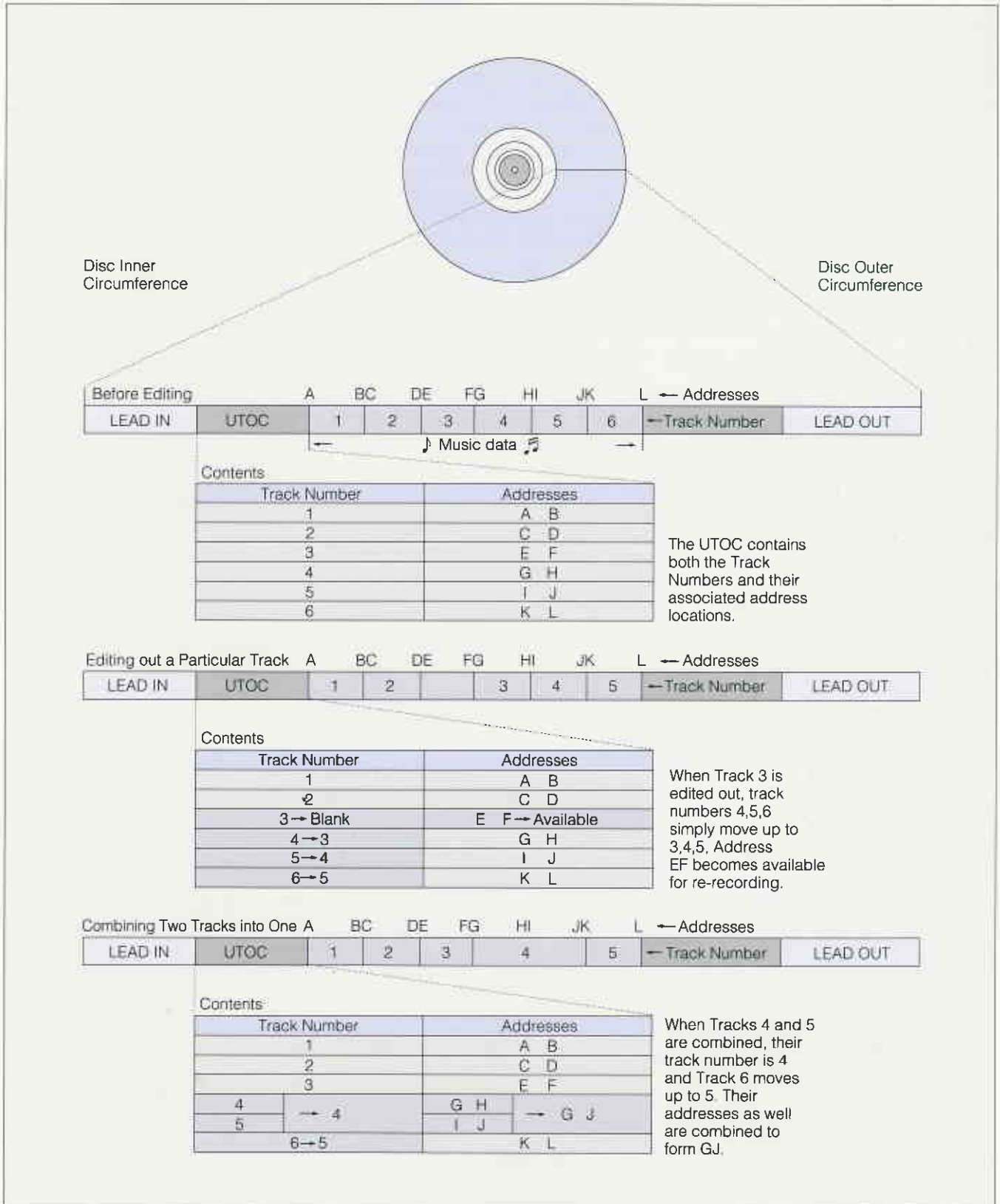

Fig. 5 Track Re-numbering Using the MiniDisc User Table of Contents (UTOC)



Signal Recording Format

The MiniDisc system uses an advanced and versatile signal format very similar to the CD-ROM mode 2 standard. Playback-only MiniDiscs have more subdata capacity than recordable MiniDiscs because link sectors are not required, allowing the recording of character information and other special features on pre-recorded playback-only MiniDisc releases.

Popular EFM and CIRC Adopted

The MiniDisc system uses the popular eight-to-fourteen modulation (EFM) in writing data on a disc, and the Cross Interleave Reed-Solomon Code (CIRC) for error correction. Audio data reduced by ATRAC is grouped into blocks for recording in a format very similar to the CD-ROM mode 2 standard, as Fig. 6 shows.

Link Sectors

In this format, 98 frames of a CD make up one sector, which is equivalent to 13.3 ms playback time. CIRC interleave length is 108 frames, equivalent to 14.5 ms, which is longer than one CD-ROM sector. Three sectors must be used as "linking sectors" to record data using CIRC error correction code, and their area is called the link area. A link area of more than 108 frames (one sector) must be provided before data is written. Similarly, an area of more than 108 frames must also be provided after the data has been written so that the error correction interleave can finish properly.

Data Utilization Efficiency

If data is written in random places, link areas will be scattered throughout the disc, reducing data utilization efficiency. Data is written only after being grouped into fairly substantial recording units called "clusters." In MiniDisc, each cluster has 36 sectors, and rewriting is always performed in integer multiples of one cluster. Data to be recorded is temporarily stored in a random access memory (RAM) before being written on the disc. Incidentally, this RAM also serves as the shock-resistant memory during playback.

Error Correction Data

The first three sectors of one 36-sector cluster are used as link sectors during recording, with the fourth sector reserved for subdata. In the remaining 32 sectors the compressed digital data is recorded. When the last sector has been written, error correction data must be written in the first link sector and half of the second sector of the following 36-sector cluster.

Mastering the Playback-only MiniDisc

In the playback-only MiniDisc, data is written in one continuous stroke, obviating the need for three sectors for a link area. Therefore, all of the first four sectors can be used for subdata, such as character information for the incorporation of lyrics or other special text. This also makes it impossible to record the entire contents, including subdata, of a play-

Fig. 6 MiniDisc Data Format Configuration

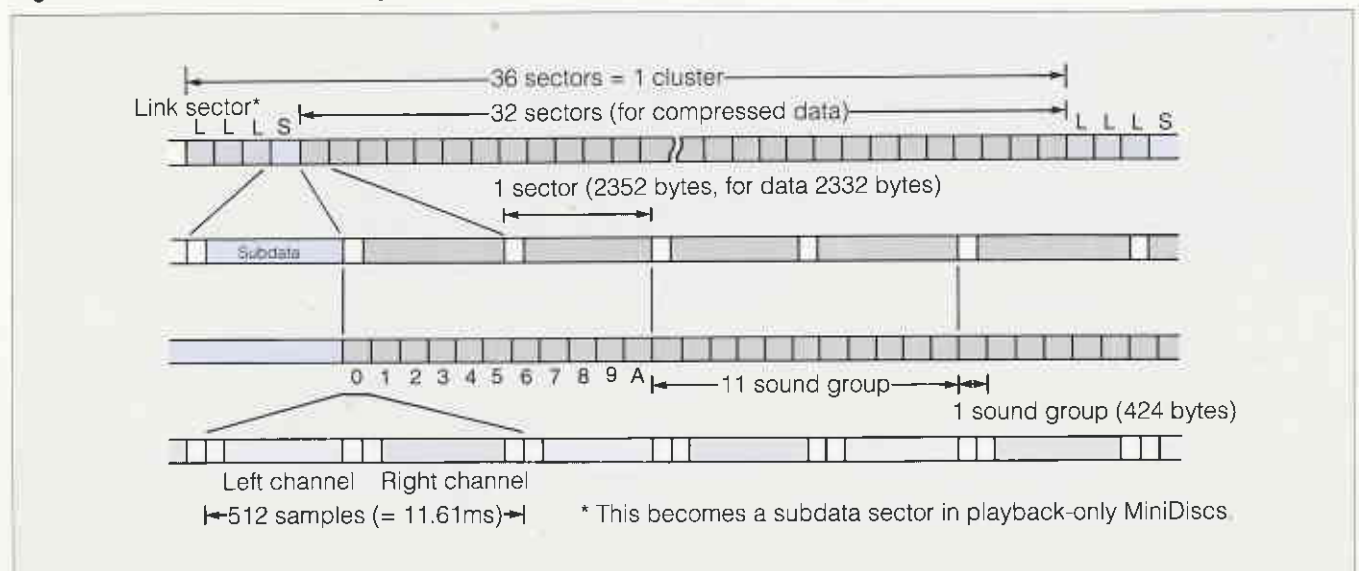

back-only MiniDisc onto a recordable MiniDisc. Thus, playback-only MiniDiscs retain some advantages over recordable MiniDiscs, as shown below.

Eleven Sound Groups Recorded in Two Sectors

During ATRAC encoding, the audio data is compressed to 1/5th its original volume, and then handled in 424-byte units called "sound groups," with left and right channels allocated 212 bytes each. A total of eleven of these sound groups are distributed into two sectors. Recorded in the first sector are the left and right channels of five sound groups, and the left channel of a sixth group, while the right channel of the sixth group and the left and

right channels of another five groups are recorded in the second sector. Each of the two sectors can be expressed as:

$$424 \times 5 + 212 \times 1 = 2,332 \text{ bytes}$$

In this manner, eleven sound groups are written per every two sectors in each 32-sector cluster. Upon playback, ATRAC decoding restores this data to its original volume and time axis, with one sound group becoming equivalent to 512 samples ($512 \times 16 \times 2/8 = 2048$ bytes) for both channels, with a playing time of 11,6 ms.

Playback-only MiniDiscs Have Certain Advantages

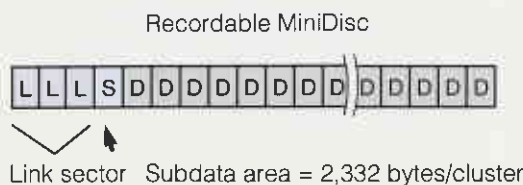
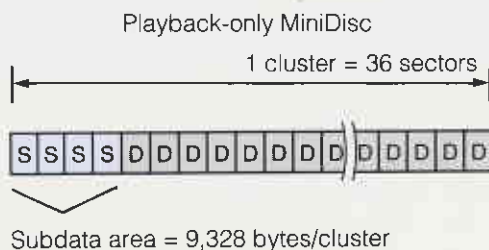
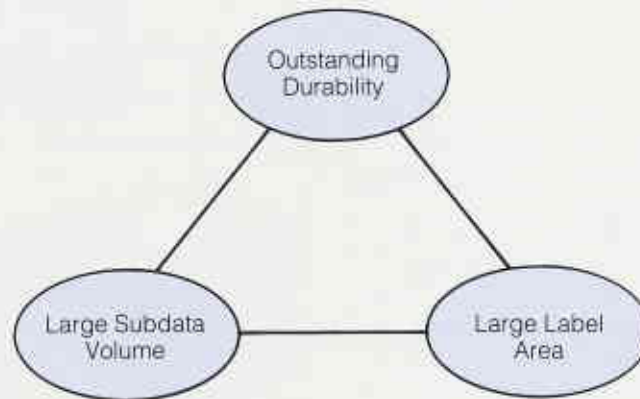

Playback-only MiniDiscs have three attributes that make them ideally suited for pre-recorded software. First, data is physically formed in pits like on a CD, and can never be erased unless it is physically destroyed. Second, since the shutter opens on only one side of the disc cartridge (rather than on both sides with the recordable MiniDisc), the label area can cover the entire front of the disc cartridge for full album artwork. Finally, playback-only MiniDiscs have about four times the subdata capacity of recordable MiniDiscs, making possible a range of value-added features such as lyrics or other text information.

Recordable & Playback-only MiniDiscs

While the capability for digital recording is a key feature in the MiniDisc format, it was also found that certain extra advantages can be obtained from a MiniDisc designed for playback only. Thus, both recordable MiniDiscs and playback-only MiniDiscs have been created to serve their specific needs.

Playback-only MiniDiscs

Designed specifically for pre-recorded music from record companies, playback-only MiniDiscs are similar to CDs in several ways. The lead-in area is on the inner circumference of the disc, followed by the program area, and the lead-out area on the outer circumference of the disc, as Fig. 7 illustrates. In addition, information in the form of pits are created on the disc substrate in the same way as CDs, as Fig. 8 shows. Moreover, discs can be stamped in mass quantities, like CDs, with an injection molding machine. For greater commercial appeal, the entire front can be used for visuals and graphics since the shutter opens only on the back side of the cartridge.

Recordable MiniDiscs

Magneto-optical technology is central to the functioning of recordable MiniDiscs. As illustrated in Fig. 9, the lead-in area is on the inner circumference of the disc, followed by the UTOC (user table of contents) area, the program area and, finally, the lead-out area on the outer circumference of the disc. Since a magnetic recording head and a laser are used on opposite sides of the disc, the shutter opens on both sides of the disc, as shown in Fig. 10. The recordable MiniDisc's unique layer structure, along with the pre-groove configuration, is represented in Fig. 11. This magneto-optical (MO) layer construction has been engineered to enable Magnetic Field Modulation overwriting, and has already been proven to endure over a million re-

Fig. 7 Cross-section of a Playback-only MiniDisc

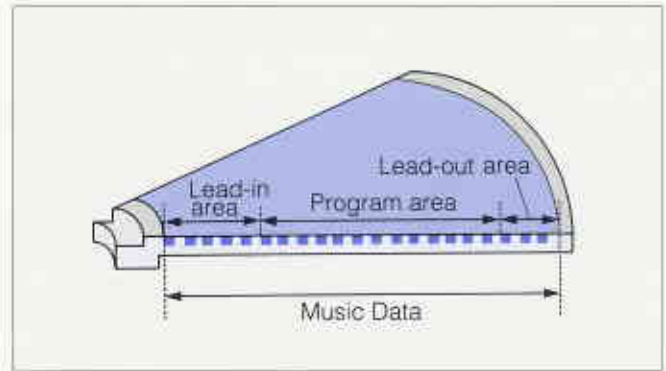
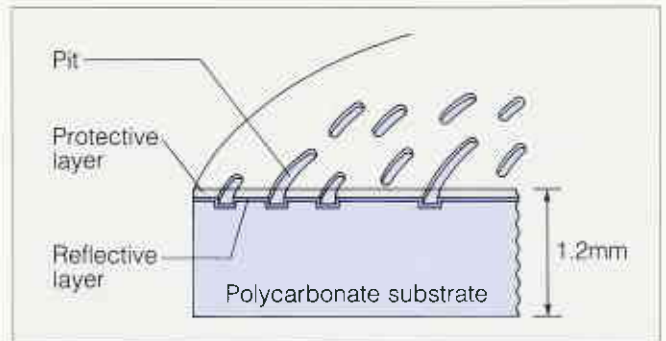

Fig. 8 Cross-sectional Representation of Disc Substrate



Recordable MiniDisc



Playback-only MiniDisc



Fig. 9 Cross-section of a Recordable MiniDisc

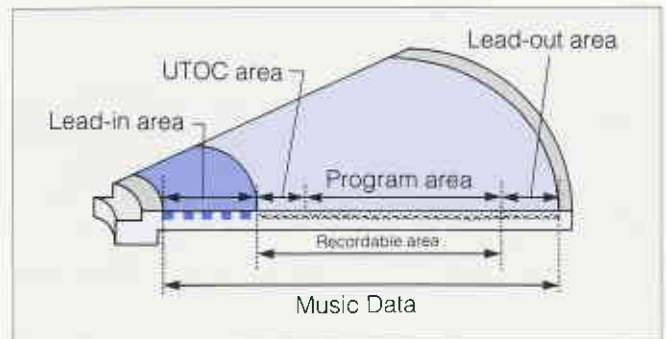

recording operations without degradation, while providing superior long-term storage characteristics. Incidentally, this same MO technology has already proven itself in computer memory applications.

Centering Via Substrate Edge

Fig. 12 is cross-sectional representation of the MiniDisc housed in its cartridge. A magnetic clamping plate is mounted in the center of the disc substrate in both recordable and playback-only MiniDiscs (which exhibit no prominent differences in this regard) to ensure that the disc is centered

when mounted by the drive unit. As in CDs, the center is aligned using the inner circumference edge of the disc substrate as a reference.

In 3.5-inch MO discs for computer data storage, a metal hub is accurately mounted in the center of the disc. Since this is costly in production, MiniDisc instead uses a magnetic plate in the center of the disc substrate to stabilize the disc inside the player. Stabilizing discs by clamping from both top and bottom (as in CDs) requires a center opening on both sides of the cartridge, but since it is not necessary for MiniDisc, the entire front side of the cartridge can be used for the label. While the disc is 1.8 mm thick along the inner circumference, the surface of the disc itself is 1.2 mm, the same as that of CDs.

Fig. 10 Exploded View of a Recordable MiniDisc

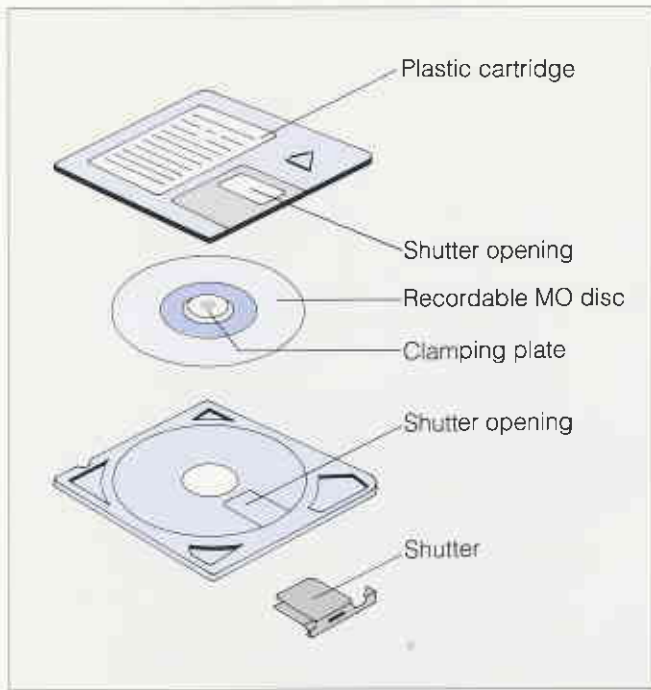

Fig. 11 MO Layered Construction of a Recordable MiniDisc

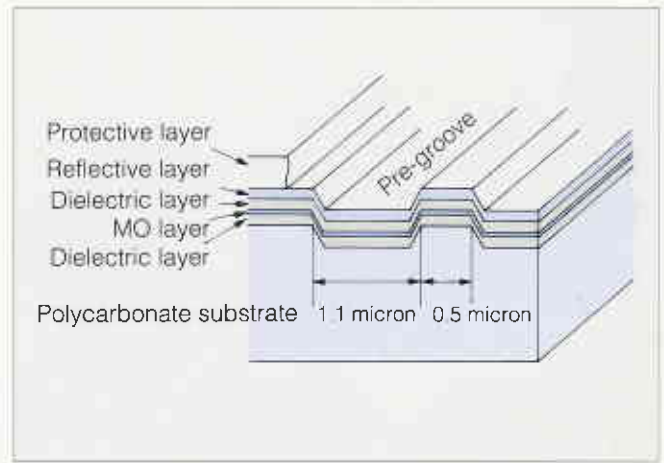
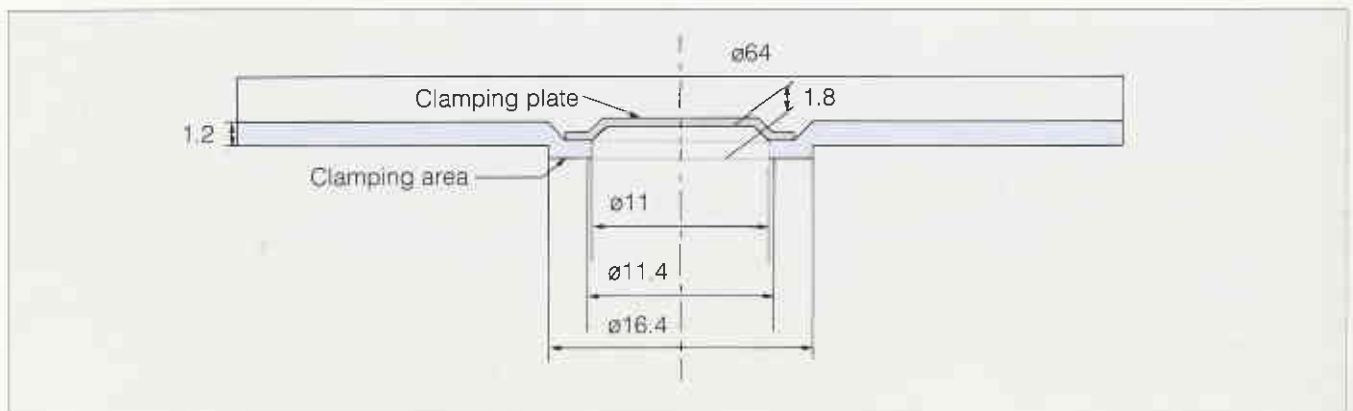

Fig.12 Cross-section of Disc and Clamping Plate



MD Pickup

Since playback-only MiniDiscs and recordable MiniDiscs are recorded in different ways, they cannot be played back with the same pickup. For this reason, the MiniDisc format makes use of an innovative MiniDisc Pickup in which both types of discs can be played back on the same equipment. The MD Pickup is based on the conventional CD player pickup, but has been modified to also contain a polarized beam splitter to detect differences in light polarization plane direction that represent signals on the magneto-optical recordable MiniDisc. Accordingly, it also has two types of photo detectors. (See Figs. 13 & 14) Moreover, the MD Pickup is very compact, and easily mass produced.

Playback-only MiniDiscs

As mentioned previously, the playback-only MiniDisc is read in much the same way as a CD, by focusing a laser beam of approximately 0.5 mW power on a series of pits on the disc. Light reflected directly back indicates the absence of a pit, while in the presence of a pit, the light is diffracted, and a lower level is reflected back to the laser. These light level fluctuations correspond to the "0" and "1" digital signals, as Fig. 13 illustrates.

Fig. 13 Playback of Playback-only MiniDisc

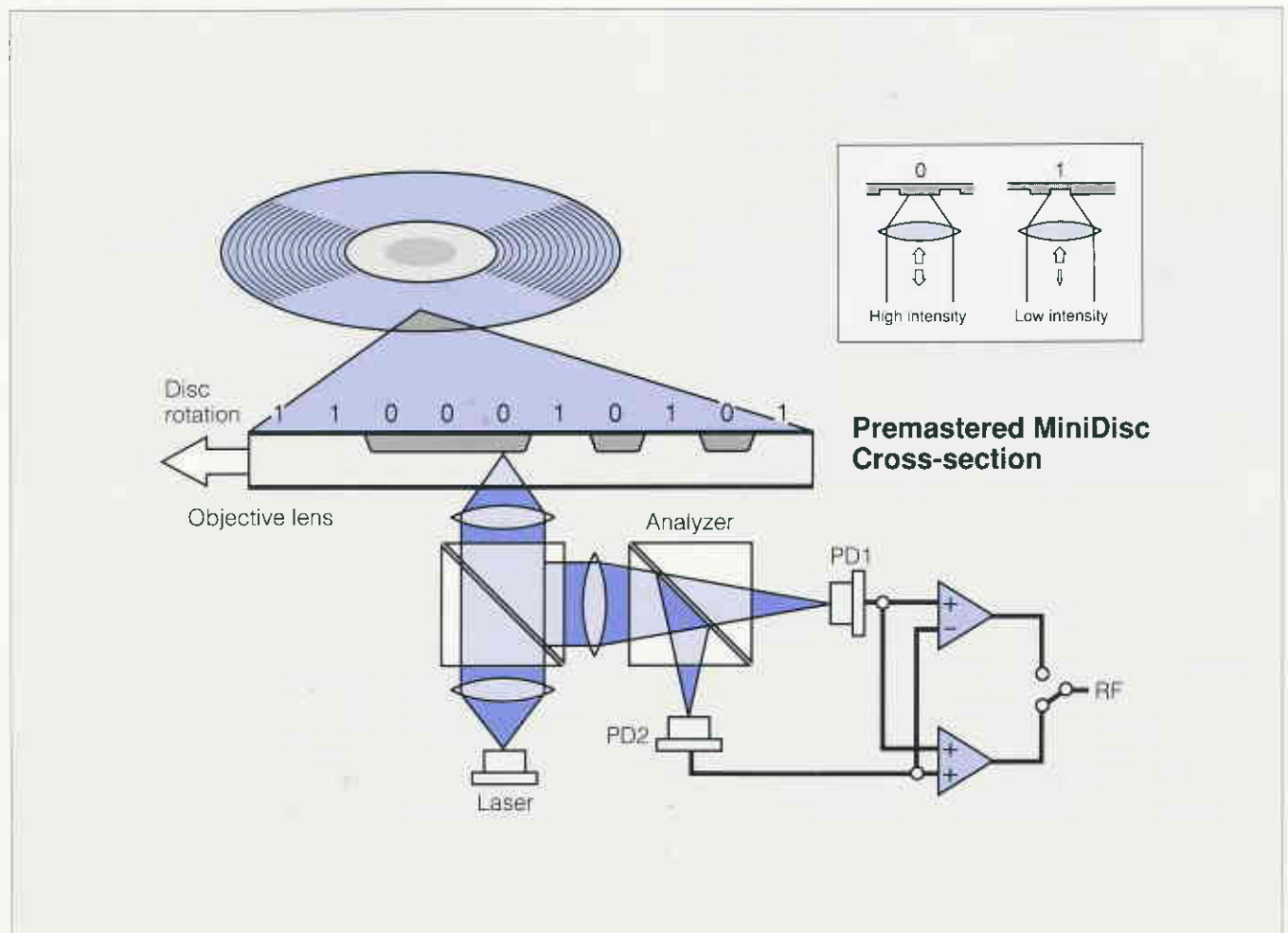

Playback of Recordable MiniDiscs

While playback of a recordable MiniDisc is also by a 0.5 mW laser, data is picked up in a somewhat different manner. Upon striking a specific portion of the disc, the polarized light will be reflected back along one of two opposing directions, with the polarization plane rotating slightly in a forward or reverse direction in accordance with the direction of the magnetic signal, in a phenomenon known as the Kerr effect. (This is illustrated in Fig. 14.) The polarization beam splitter varies the distribution

ratio of the reflected light to two photo detectors in accordance with the polarization direction. If the reflected light varies in the forward direction, more light is reflected to one photodiode; if reflected light varies in the reverse, the other photodiode receives more light. The differences in electrical output of the two photodiodes are thus used to recreate the "1" and "0" digital signals. Note that the fact that light reflected from the disc differs according to magnetic orientation is central to the recording/playback capability of MiniDisc.

Fig. 14 Playback of a Recordable MiniDisc

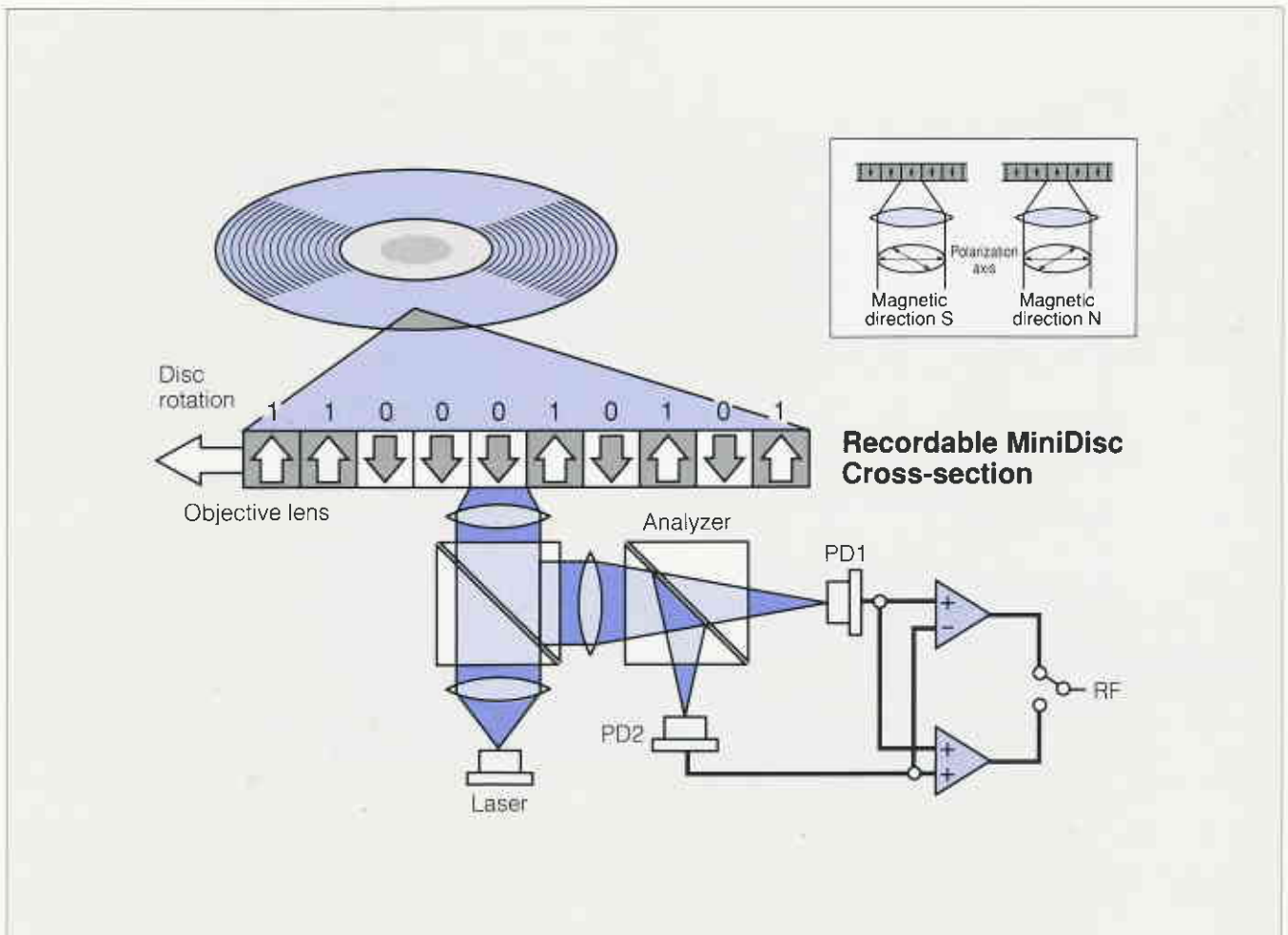

ATRAC Data Compression

Since MiniDisc was designed for portable audio, it was made smaller than a CD. At this small size, however, it can hold only about 1/5th of the data of a CD, and if it were recorded the same way, playing time would only be about 15 minutes. The MiniDisc, however, is recorded using Sony's Adaptive Transform Acoustic Coding (ATRAC) system (Fig. 15), which was designed specifically for high fidelity audio using the latest in digital data compression technology. ATRAC is based on a unique non-uniform frequency and time splitting concept, which allows the MiniDisc to adapt to the full range of audio signals. As a result, ATRAC allows MiniDisc to offer the same 74-minute recording and playback time as a CD, with virtually no loss in sound quality.

Quantization Noise

When music is recorded onto a MiniDisc, it is slightly different from the same music recorded on a CD. This difference is due to increased levels of quantization noise resulting from the MiniDisc's smaller size. If this quantization noise is rendered inaudible, then the sound will be as good as a CD. One ATRAC feature is its ability to make use of psychoacoustic principles (the way humans actually perceive sound) to minimize the audibility of quantization noise.

Psychoacoustic Principles

The sensitivity of the ear depends on frequency; it is most sensitive at around 4 kHz, and least sensitive toward the higher frequencies. A tone at a given power that is audible at 4 kHz might not be audible at another frequency. In general, two tones of equal power but of different frequency will not sound equally loud. For this reason, quantization noise is less audible at some frequencies than at others.

Another important psychoacoustic principle is simultaneous masking. A soft sound can be rendered inaudible by a louder sound, in much the same way that a conversation becomes inaudible when a train goes by. Masking is strongest when the frequencies of the two sounds are close together. This means that quantization noise is less audible at frequencies on, or closely adjacent to, loud tones.

Fig. 15 ATRAC Operation Layout

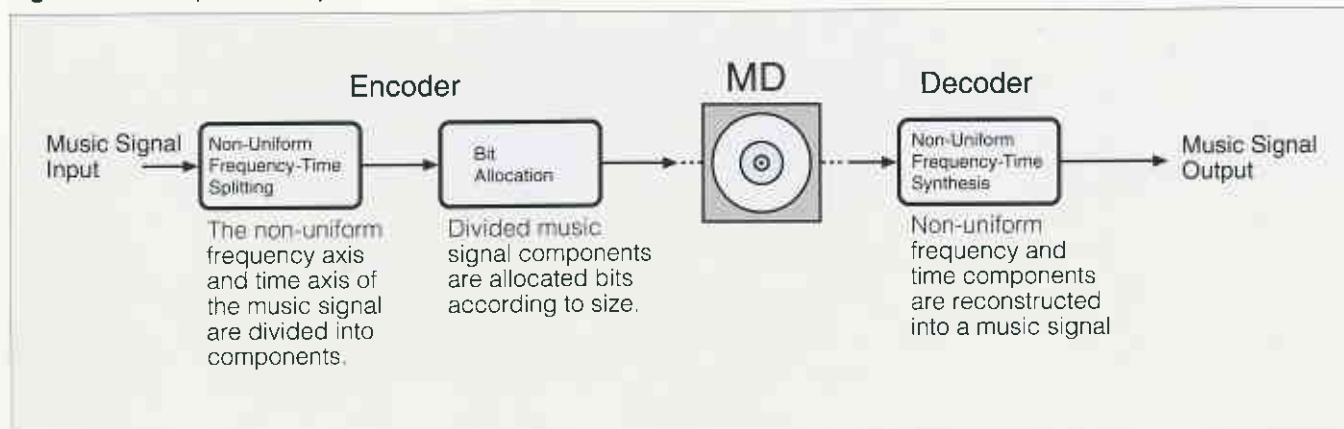

ATRAC makes use of these scientifically proven psychoacoustic principles to adapt the audio signals to the ear's changing sensitivity. It operates in such a way to "hide" quantization noise in frequency regions where there are high signal levels corresponding to a lot of musical activity. This effectively renders it inaudible.

For each block of time, ATRAC analyzes the music signal and determines the sensitivity of each frequency region. The sensitive regions are recorded accurately, with very little quantization noise. The remaining regions are recorded less accurately, but since they are not too sensitive, the quantization error is hardly noticeable (Fig. 16). The result is high fidelity audio in actual listening, recorded at only 1/5th the bit rate.

Non-Uniform Frequency and Time Splitting

ATRAC's frequency and time divisions are shown in Fig. 17. Notice that the frequency divisions are not of uniform width. These divisions are based on another important psychoacoustic concept called critical bands, in which the ear perceives different frequencies using a series of these critical bands of varying widths. Critical bands are essential for understanding the loudness of quantization noise. The width of a critical band increases with frequency; at 100 Hz it is 100 Hz wide, at 1,000 Hz it is 160 Hz, and at 10,000 Hz it is 2,500 Hz. Because of this phenomena, ATRAC has been designed to analyze sounds in non-uniform frequency divisions, with more divisions in the lower frequencies and fewer in the higher frequencies, to ensure greater accuracy in signal analysis.

Fig. 16 ATRAC Effective Bit Allocation

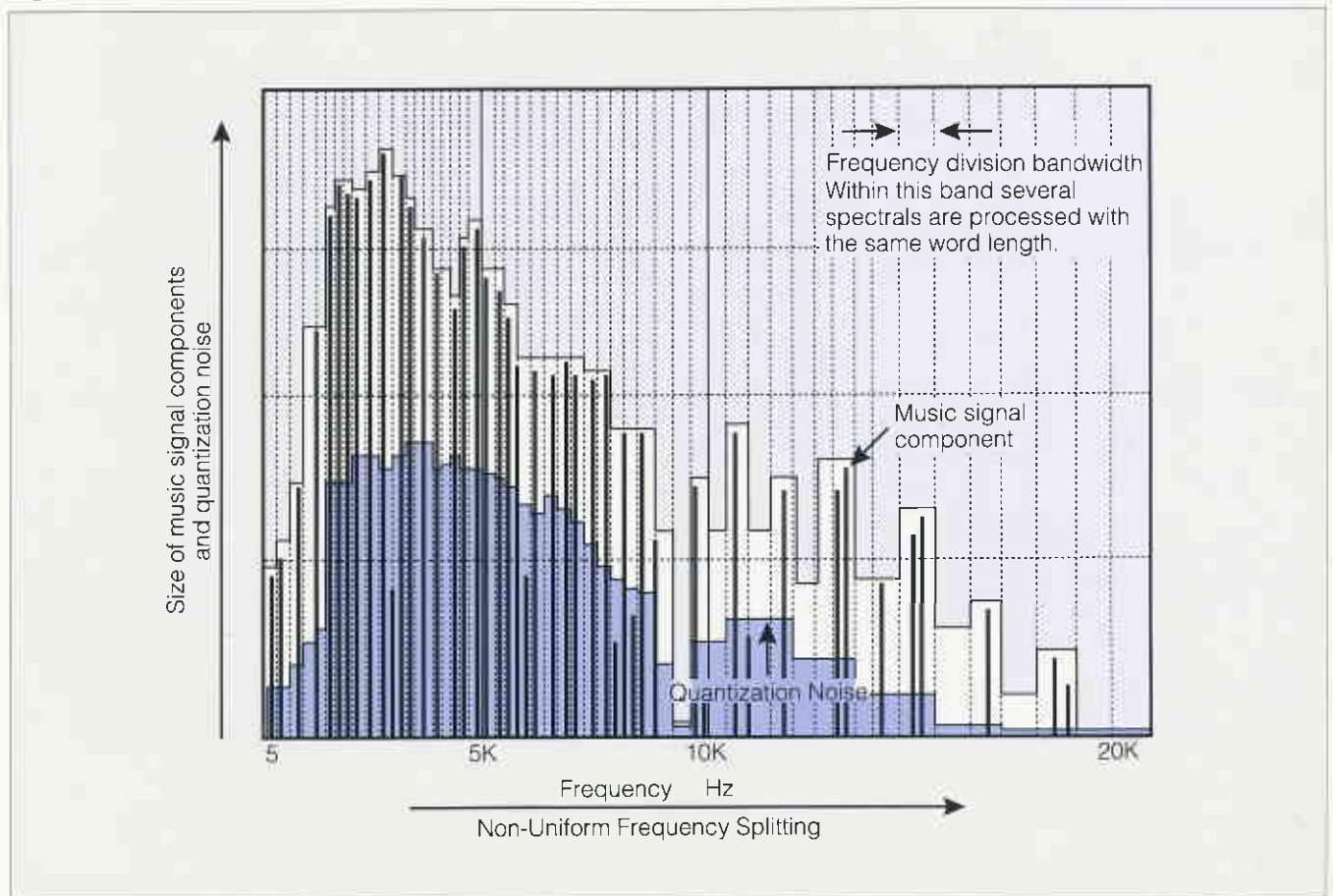

ATRAC also features non-uniform time splitting. Since music signals are constantly changing, ATRAC analyzes them in extremely short blocks of time. When the music is changing quickly, as in particularly vivid passages, the sensitivity of the ear also changes quickly, so ATRAC splits time up into short blocks of only 1.45 or 2.9 ms to keep up with the music. When the music changes slowly, as in rather stationary passages, the time can be split into longer blocks of up to 11.6 ms because the sensitivity of the ear also changes more slowly. The use of these longer time blocks enables the use of narrower frequency bands, leading to improved frequency resolution and higher sound quality. ATRAC's active flexibility in using either short or long time blocks is the key to realizing greater

efficiency in data compression encoding, while controlling quantization noise.

Modified Discrete Cosine Transform (MDCT)

In order to achieve non-uniform time and frequency splitting, ATRAC uses a unique combination of filters and transforms, as illustrated in Fig. 17. Two splitting filters are used to divide the original signal into three sub-bands:

- low (0 – 5.5 kHz),
- medium (5.5 – 11 kHz), and
- high (11 – 22 kHz).

These signals are then transformed into frequency values by Modified Discrete Cosine Transform

Fig. 17 ATRAC Non-Uniform Frequency-Time Splitting

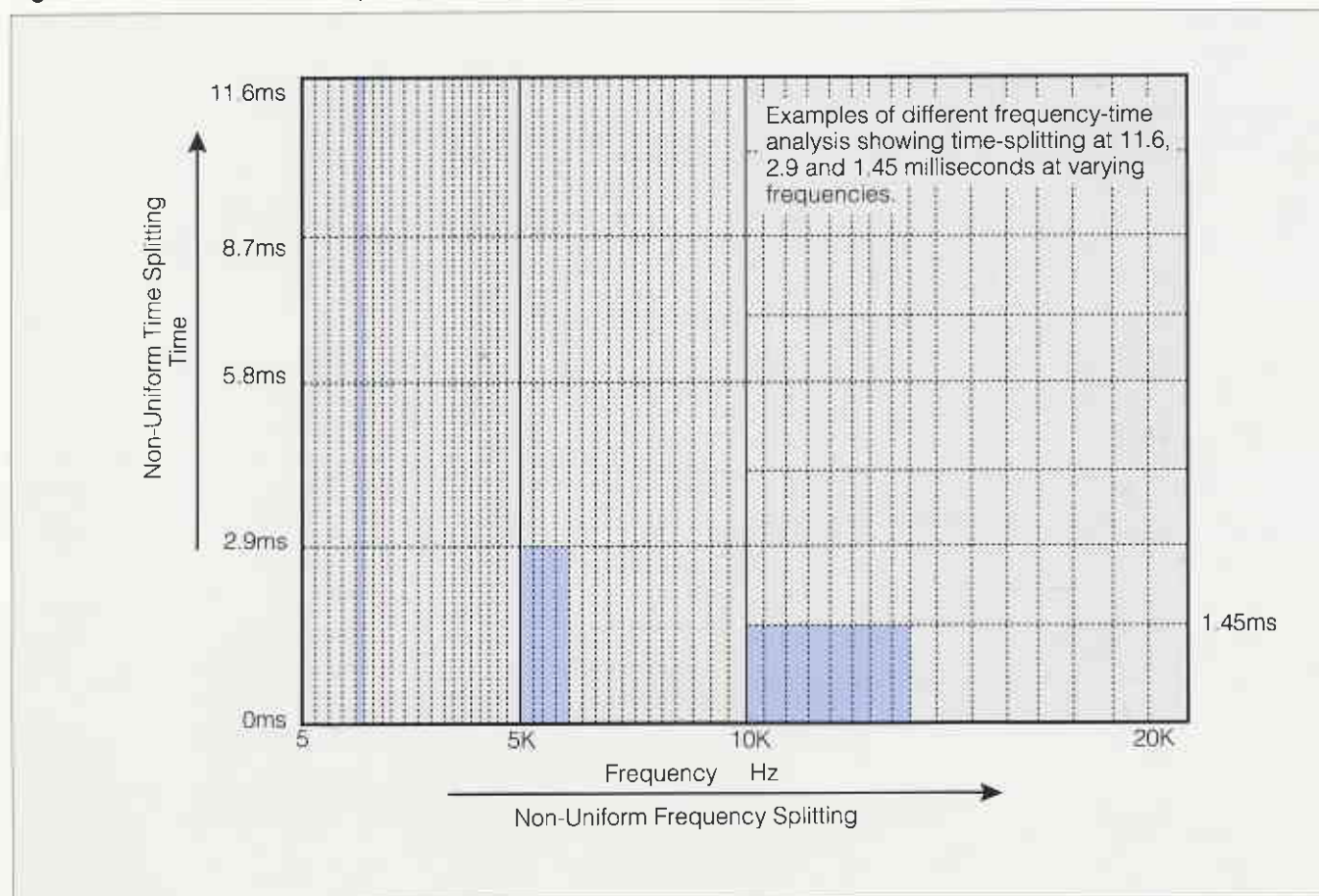

(MDCT) operation. Before MDCT is performed, however, the signals are analyzed to determine if they are changing quickly or slowly. As described above, if the signal is changing quickly, then the MDCT uses a short time block; if the signal is stationary, a longer block is used for improved frequency resolution.

Once the signal is expressed in terms of frequency, the MDCT values are formed into 52 non-uniform frequency groups. These groups must be requantized to reduce the bit rate, and this is done according to the masking and sensitivity characteristics of each group. A special block floating algorithm is used to eliminate any wasted high-order bits, such as when a 5-bit value is represented by an 8-bit number. In this way, the data wordlength is

reduced top and bottom while avoiding audible degradation of the music.

The decoder reverse the process by first reconstructing the MDCT frequency values back into time values by inverse MDCT operation. Finally, the three sub-bands are combined to obtain a normal 16-bit digital audio signal.

In this way, ATRAC takes advantage of psychoacoustic principles in performing non-uniform frequency and time splitting to achieve a highly advanced method of data compression. As such, ATRAC enables the MiniDisc format to realize a high level of operability and sound quality.

Fig. 18 ATRAC Frequency Analysis Circuit Construction

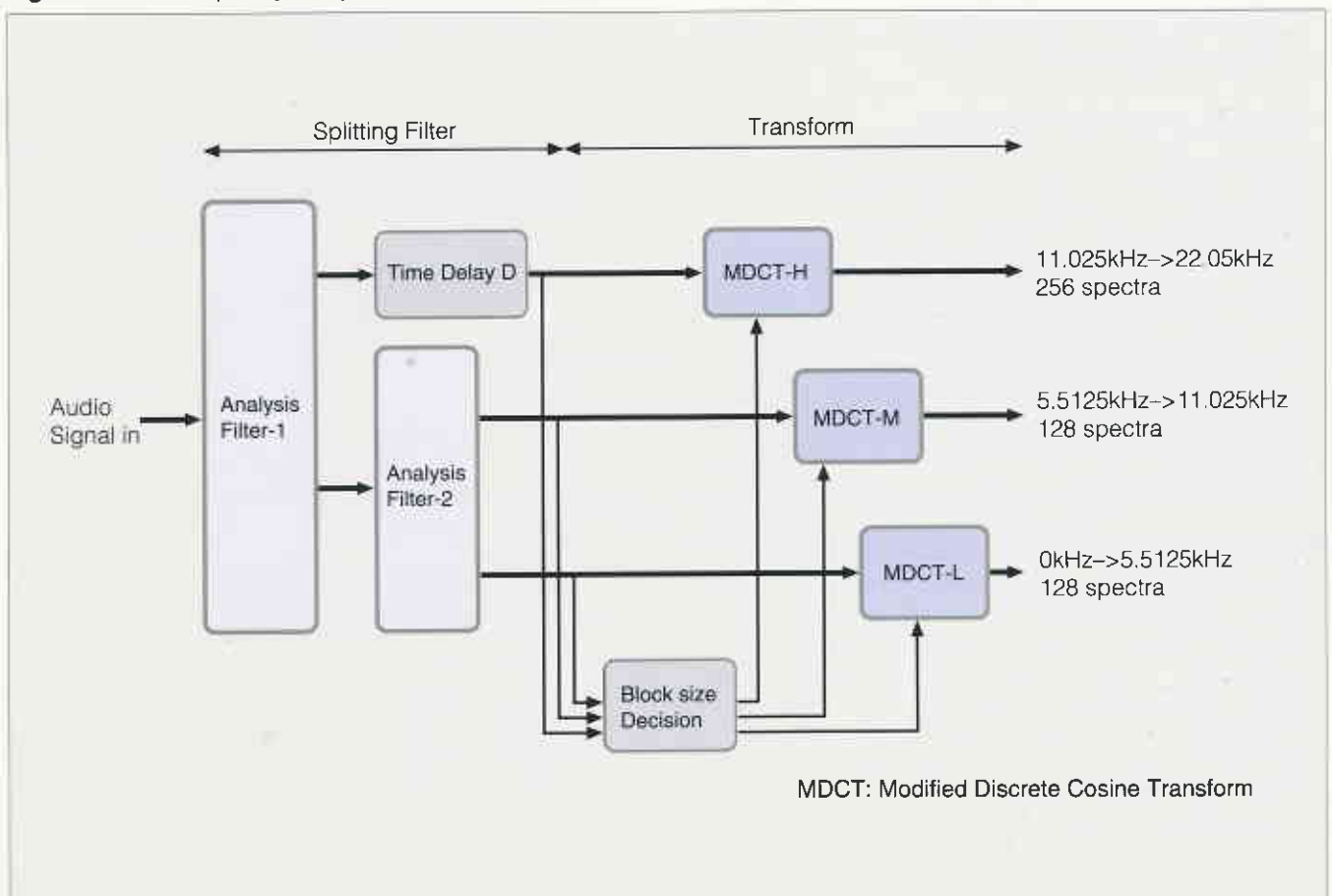

Magneto-Optical Recording

While magneto-optical recording systems that enable recording on a disc one time only have existed for some time, a key requirement in the design of the recordable MiniDisc was that it can be recorded over a virtually unlimited number of times. Another requirement was that the hardware be light and compact, and have low power consumption, to make portable application practical. To realize these requirements, two significant technical breakthroughs were achieved.

- 1) The development of a highly stable magnetic disc layer of terbium ferrite cobalt that permits flux reversal using a low-level magnetic field of 6.4 kA/m (80 Oe) (about 1/3 that of conventional magneto-optical discs) to allow the use of a small magnetic head which produces a weak magnetic field.
- 2) The development of a magnetic head and related technology that allows virtually instantaneous magnetic flux reversal (in approx. 100 nanoseconds) at low power consumption levels. This solves the problem of temperature increases inside the system, while low power consumption enables battery powered operation.

Principles of MO Disc Recording

A magneto-optical disc can be re-recorded a virtually unlimited number of times through a method based on the principle of opto-thermal magnetic recording. A given spot on the magnetic layer is heated with a laser beam to a point above the Curie temperature (which varies depending on the magnetic material involved), which effectively dissipates its magnetization. The disc continues rotation, and once away from the laser beam, the spot begins to cool. A magnetic field is then applied to the spot to orient it to either N or S polarity, corresponding to the "1" and "0" of digital signals.

Data Rewriting on a Conventional MO Disc

On conventional MO discs used for computer data storage, all previously recorded signals must be erased before new data can be recorded. In principle, the track to be re-recorded must be heated (by a laser) while applying a magnetic field to re-orient all magnetism in the same direction, effectively erasing it. Previous systems have primarily used two methods to accomplish this.

1. Two lasers are used, one for erasing and one for recording, just like a tape recorder with an erase head and a head for recording. (Fig. 19)

Fig. 19 Data Rewriting with Two Lasers in One Rotation

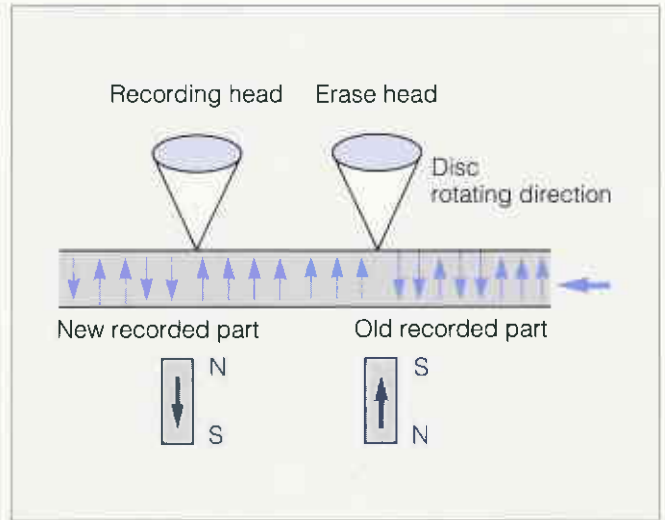
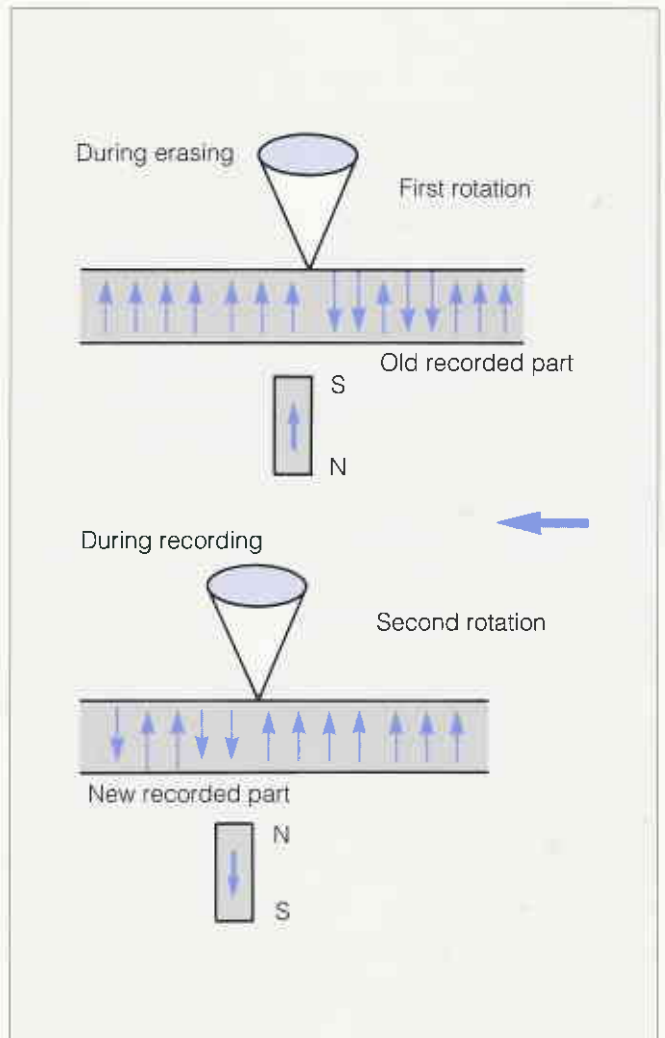

Fig. 20 Data Rewriting with One Laser in Two Rotations



2. A single laser is used for these two tasks, with old data erased in the first rotation, and new data recorded in its place on a second rotation. (Fig. 20)

The problems encountered in these two approaches were that either two lasers were required, or roughly twice the recording time was required in a system needing a rather complex servo-mechanism.

Magnetic Field Modulation Overwrite System

In order to avoid the large and complex systems necessary with conventional magneto-optical disc technology, MiniDisc uses a Magnetic Field Modulation overwrite (MMO) system that writes new signals over old signals. This system gets its name because it modulates the magnetic field at high speed to create specific magnetic orientations to represent the input signal.

MMO System in Operation

The MMO system uses a magnetic head on one side of the disc, and a laser beam on the other side of the disc in the corresponding position. With the disc between the magnetic head and the laser, the

magnetic head creates a magnetic field, corresponding to the signal, opposite the spot upon which the laser is focused. The laser brings this spot up to the Curie temperature point, which dissipates its previous magnetic orientation. As this spot on the disc moves away from the laser, it cools to below the Curie temperature, and a new magnetic orientation corresponding the input signal is created by the magnetic head.

Consistent Resolution for Increased Accuracy

Since the size of the magnetic signals recorded on the magneto-optical layer of the disc are controlled by magnetic flux reversal, rather than by switching the laser on and off, the MMO system results in magnetic signals of consistent resolution for greater accuracy. In particular, it is now easy to achieve accurate recording of short wavelength signals, a previously difficult task due to thermal diffusion and other problems. Moreover, the MMO system requires the laser to continually radiate a beam during both recording and playback, which allows a more simplified optical head, contributing to lighter and more compact hardware designs.

Fig. 21 Magnetic Field Modulation Overwrite System

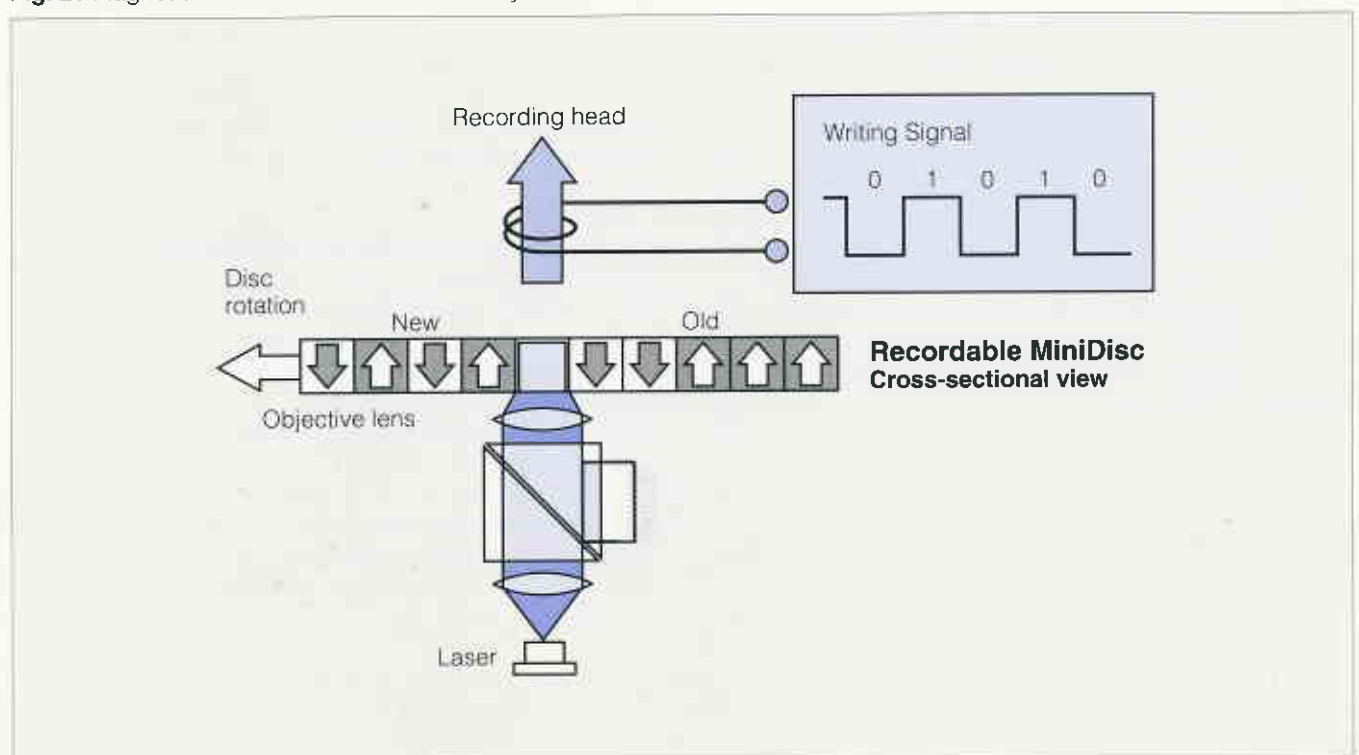

Magnetic Field Modulation

Recordable MiniDisc uses magnetic field modulation for magneto-optical recording, a technology originally developed for CD-MO, a rewritable CD format. Magnetic field modulation exhibits the following key advantages:

- 1) Rewriting capability enables re-recording**
- 2) High recording density of 0.6micron/bit**
- 3) Pit-edge modulation is ideal for CD-standard EFM signals**
- 4) Less jitter because linear velocity is less critical**
- 5) Wider recording power margin**
- 6) Superior resistance to disc tilt**

Rewritable Vs. Write Once Recording

There are two types of recordable optical discs, the Write Once (WO) type which can be recorded only once, and the rewritable type which can be re-recorded any number of times. For consumer audio use, the rewritable type is far more preferable for a number of reasons.

Since few users re-record music several times on one analog cassette tape, it has been suggested that a WO disc is sufficient. However, if a recording fails to start properly, or the levels are not set properly, users will start over and record from the beginning of the tape. Moreover, many people make trial recordings to confirm recording levels and bias settings, then rewind the tape and re-record from the start. Naturally, this is not possible with a WO disc, which is why a rewritable type was chosen for the recordable MiniDisc.

There are several different types of rewritable optical discs, each with their own recording characteristics. The most popular are the magneto-optical type and the phase-change type. There is also a type which uses organic dye polymer film. Since the phase-change type has a narrow power margin, and the dye polymer type has a limited rewriting life, the recordable MiniDisc uses the magneto-optical (MO) type disc, which is being used most widely in computer data storage.

MO Recording with Magnetic Field Modulation

In developing the CD-MO, a magneto-optical disc which can record signals in the same format as CD, Sony set three practical goals: 1) rewriting capability, 2) recording at the same density and linear velocity as CD, and 3) the ability to format addresses on the disc in advance.

Rewriting capability is essential for the continuous recording, in real time, of audio signals onto a previously recorded disc. While laser modulation recording is used in magneto-optical systems for data storage, it is not applicable for MiniDisc because it erases and records data as separate operations. Instead, Magnetic Field Modulation was adopted for recordable MiniDisc.

Achieving the same recording density as CD initially seemed to be a difficult task, but would be possible if recording could be performed at the same linear velocity of 1.2–1.4 meters/second (m/s). Incidentally, CDs boast the highest recording density among all optical discs on the market today. The signal pits on a CD are remarkably small, and are formed by focusing an argon laser with a 460nanometer wave length through a NA=0.9 lens, resulting in a spot diameter of 0.4 microns. But for the system being developed for MiniDisc, only a semiconductor laser with a 780 micron wave length focused through a NA=0.45 lens could be used, which would result in a larger spot diameter of 0.9 microns. Thus, with this larger light spot, achieving the same recording density as CD was in question.

To enable pre-formatting of addresses, a slightly wavering pre-groove was adopted which forms absolute addresses throughout the disc at 13.3 ms intervals.

Highly Symmetrical Recording Patterns

When experimenting with recording CD signals by conventional laser modulation, it was found that even when linear velocity was reduced to 1.2 m/s, erroneous blocks of data still occurred at the rate of 200 per second, barely above the minimum standard for CD. Using Magnetic Field Modulation, however, resulted in an erroneous block rate of only 20 per second, even at a linear velocity of 1.2 m/s (Fig. 22). Magnetic Field Modulation is not only capable of rewriting signals, it is also suitable for recording CD signals at the same linear velocity.

Magnetic Field Modulation Vs. Laser Modulation

The differences between laser modulation and Magnetic Field Modulation, in this instance, can be attributed to the differences in their resulting recording patterns.

In Magnetic Field Modulation, a semiconductor laser continuously radiates at a power of about 4.5

milliwatts (mW), and when focused on a spot, raises its layer surface temperature to the Curie temperature (about 180 degrees C or 356 degrees F). After the laser passes, the temperature drops. This process is then repeated, with the introduction of a magnetic field in one of two different orientations to the spot. Depending upon the orientation, either "1" or "0" is recorded, with the boundary being the isothermal line of the Curie temperature. This determines the shape and length of the recorded "1" and "0" pattern, as Fig. 23 illustrates.

If the magnetic field can be inverted quickly enough, it is possible to write patterns at a pitch of only 0.3 microns, even with a laser of 780 micron wave length focused through a NA=0.45 lens. Furthermore, the resulting pattern is highly symmetrical, which is one characteristic advantage of Magnetic Field Modulation.

Laser modulation, on the other hand, records signals by varying the degree of laser power. A magnetic field can only be oriented in one direction, with the area exposed to laser light corresponding to "1" and the unexposed (un-recorded) area corresponding to "0." This results in irregularly shaped recorded patterns. When attempting to record CD signals with such patterns, increased jitter will result. This occurs because pit length varies in CD signals recorded by EFM, and when a pattern corresponding to a long pit is recorded at a slow linear velocity of 1.2-1.4 m/s using laser

Fig. 22 Block Error Rate with Magnetic Field Modulation

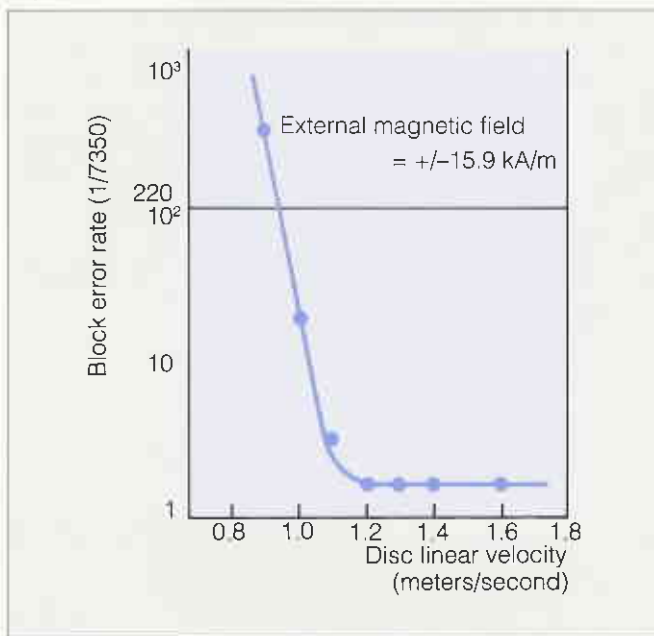
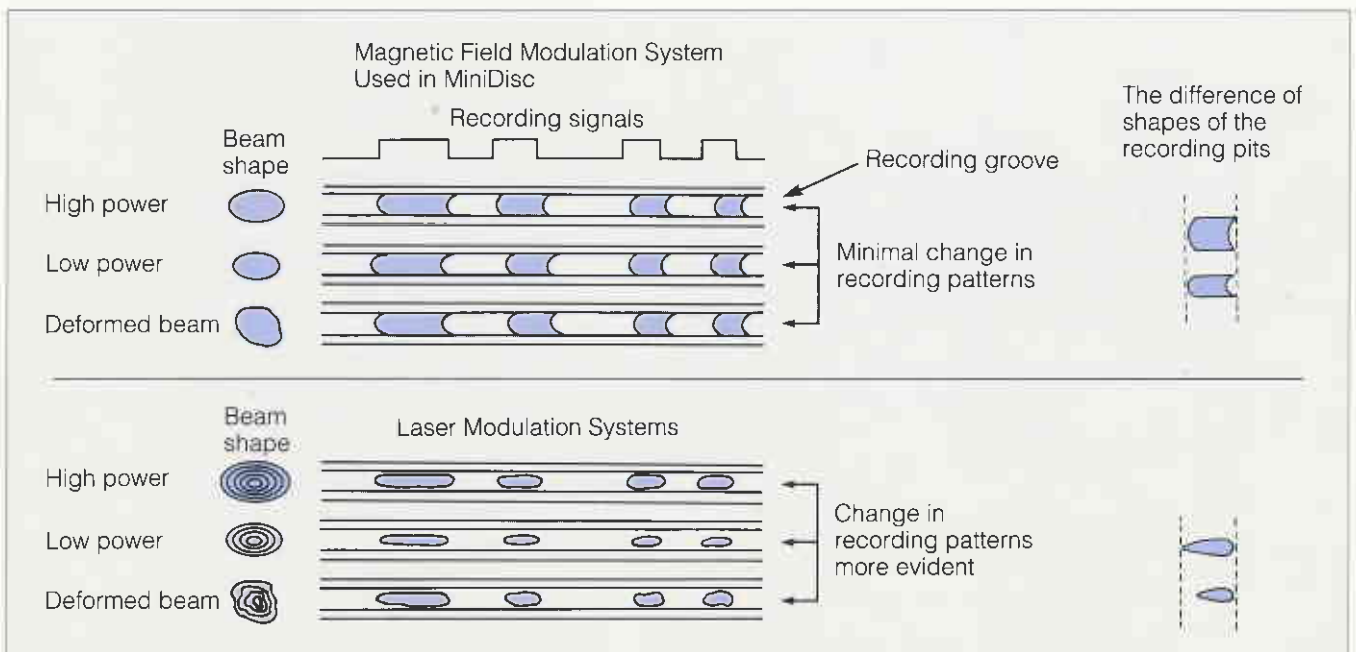

Fig. 23 Comparison of Recorded Patterns



modulation, the latter half will become thicker, as shown in Fig. 23, creating a shape like a tear drop. This is because heat from the laser easily accumulates in the latter half. Shapes like this result in increased jitter upon playback. This problem, however, can be solved by pulsed laser output.

Another problem with laser modulation is that fluctuations in recording power can easily distort the start and finish locations of the recorded pattern, causing time-axis jitter upon playback. This increases asymmetry, or second-order harmonic distortion. Since Magnetic Field Modulation creates highly symmetrical recording patterns, these problems are unlikely to occur. Moreover, in terms of block error rate variation by recording power fluctuation (Fig. 24), the Magnetic Field Modulation system can tolerate a fluctuation of $\pm 20\%$, while with the laser modulation system can only tolerate at $\pm 10\%$ fluctuation.

Resistance to Disc Tilt

Magnetic Field Modulation has an additional advantage of being highly resistant to disc tilt. When the disc is off its axis, the laser light spot on it becomes distorted. Laser modulation is more vulnerable to disc tilt because the laser light spot determines the shape of the recorded pattern. In Magnetic Field Modulation, however, a laser is used only to raise the temperature of the magneto-optical layer on the disc, and does not determine the shape of the recorded pattern. Therefore, there is less effect during recording when the laser light spot is distorted because of disc tilt. This is confirmed by the data in Fig. 25, in which Chart (a) shows the variation in block error rate when the disc is tilted in the radial direction. Even at ± 1.5 degrees, the block error rate remains stable as long as there is no change in tilt. Similar results are shown in Chart (b), when the disc is tilted in the longitudinal direction, parallel to the track.

Fig. 24 Block Error Rate By Variations in Recording Power

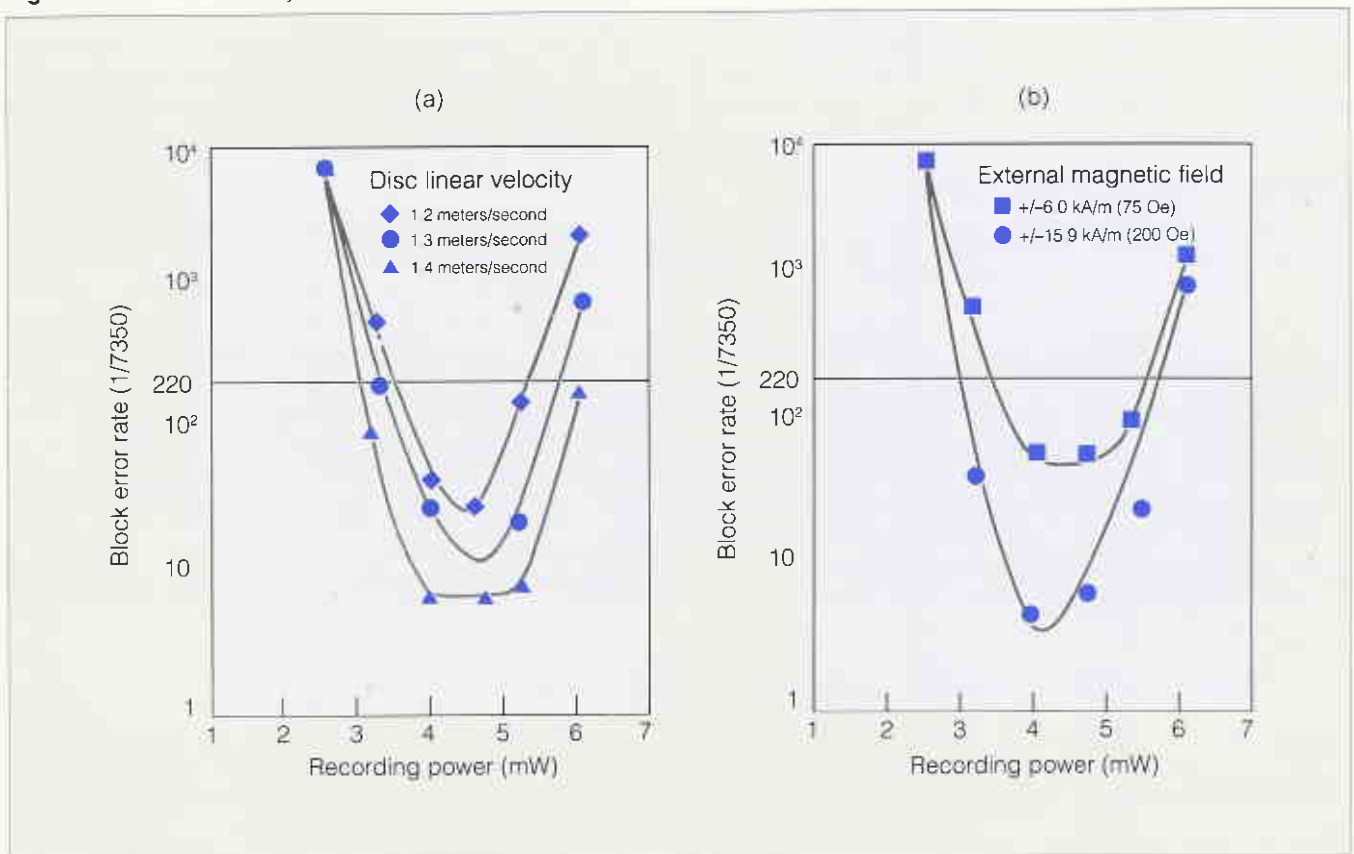

Magnetic Head Easily Applied

Despite the many advantages of Magnetic Field Modulation, it has not found practical application in magneto-optical disc systems for computer data storage because of the difficulty in creating a suitable magnetic head. To obtain sufficient data access speed, magneto-optical discs for data storage must be rotated at high linear velocity speeds in excess of 10 meters/second. To record data at such speeds, the magnetic field must be reversed at rates in the tens of MHz — a frequency which is difficult to obtain with magnetic heads. Fortunately, CD linear velocity is as slow as 1.2 - 1.4 meters/second, requiring a magnetic reversal frequency as low as 720 kHz, which is easy to obtain with a magnetic head.

Single-sided Disc Recording

Magnetic Field Modulation allows the use of only one side of the disc for data recording, which could be considered a shortcoming. For consumer equipment, however, a less-expensive single-sided disc is more acceptable because the production cost for a double-sided disc would be more than twice as high.

Fig. 25 Superior Tilt Resistance

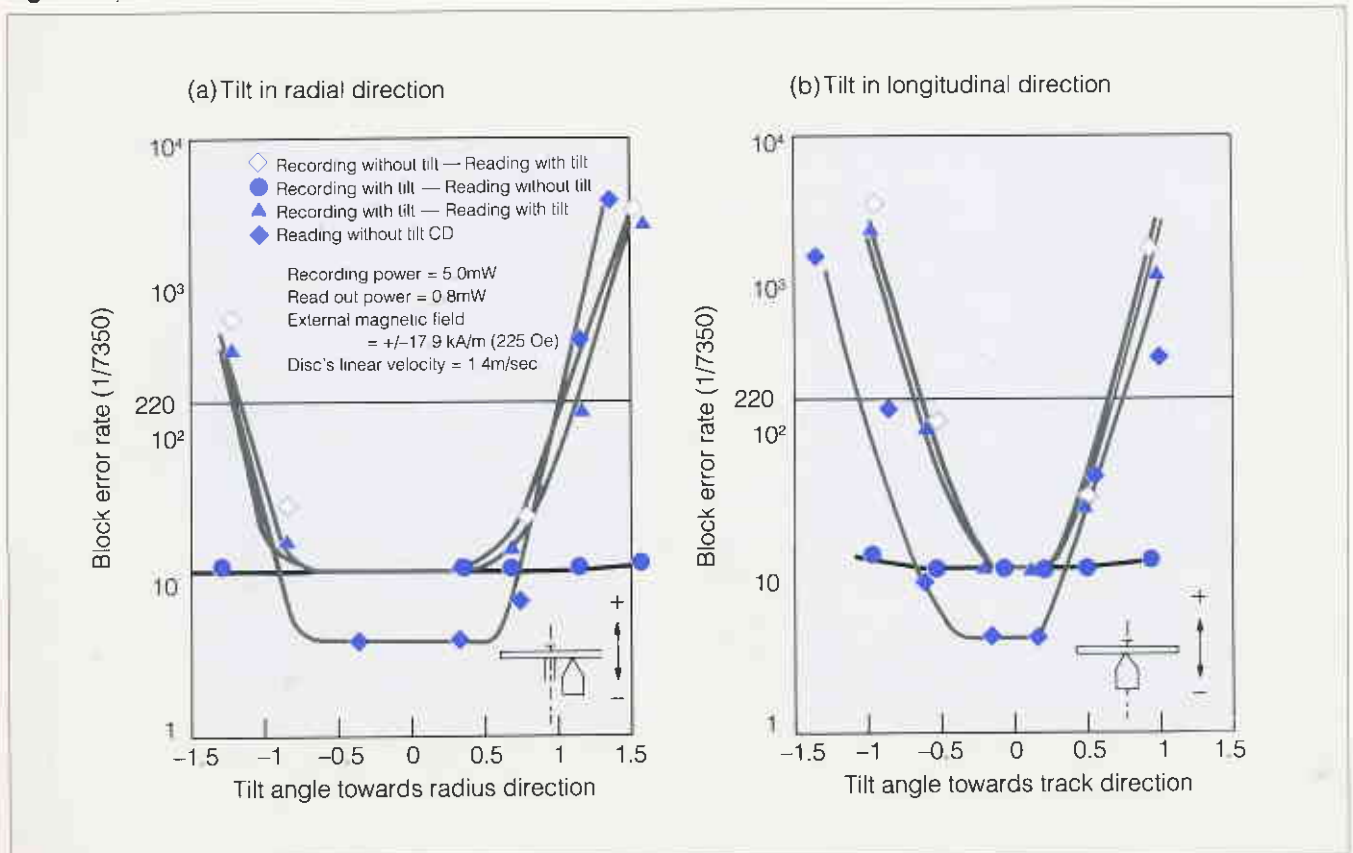

MiniDisc Mastering Systems

Success in marketing the MiniDisc format will involve the simultaneous release of pre-recorded MiniDisc software by record companies. Therefore, it was essential to create a mastering system for playback-only MiniDiscs.

Like CDs, playback-only MiniDiscs feature both playing time and subdata capacity, so basic production methods are the same in regard to the handling of these two features. Therefore, a significant advantage is that CD mastering systems now in use, including the 3/4" U-matic type cassette media used for mastering, can also be used for pre-recorded MiniDisc software. At present, most CD mastering systems, from studio premastering to mastering at pressing plants, are primarily comprised of Sony equipment.

MiniDisc Premastering at Studios

A basic premastering system for MiniDisc is shown in Fig. 26.

The 3/4" cassette of the CD master is also used for MiniDisc mastering, and is played back with a digital master recorder and digital audio processor, with playback signals checked by a digital tape analyzer. The corrected 16-bit audio signals are then input into a format converter unit and recorded onto a hard disk after data compression, with monitoring performed by simultaneously decoding the data-compressed signal into a normal 16-bit audio signal. Subdata recorded on analog track 1 is recorded onto the hard disk after also being input into the format converter unit.

With MiniDisc, information such as song titles can be entered by inputting the data with a keyboard or PC. Subdata previously recorded onto the hard disk is converted to MiniDisc format signals with the compressed audio signals. The data is then copied onto a 3/4" digital audio master cassette tape, which becomes the MiniDisc master tape, while a digital tape analyzer checks for errors and outputs an error check sheet through a printer. Finally, song titles and other subdata information can be printed out, and sent with the master tape to the pressing plant, together with the error check sheet for confirmation.

Fig. 26 MiniDisc Premastering System

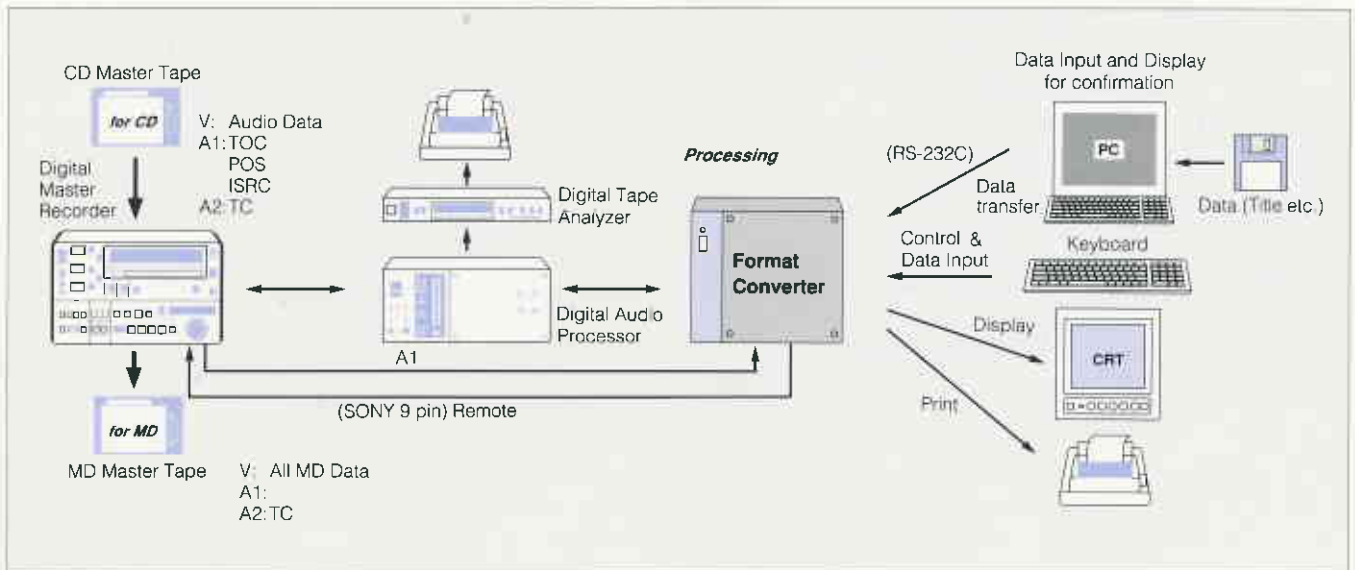

CD Mastering at the Pressing Plant

A typical CD mastering system at a pressing plant is shown in Fig. 27. The CD master tape from the studio is played back on the digital master recorder, with errors checked by a digital tape analyzer. The corrected digital audio signals are input into a compact disc code processor. The subdata information from analog track 1 is sent to a cue editor for conversion into PQ subcode data, then input into the compact disc code processor. In the compact disc code processor, the error correction code is processed for the 16-bit audio signals, which are then combined with sub-code data for format conversion processing, then modulated. A sync signal is then added to obtain CD format signals for input into the mastering machine. This completes the production of a CD master disc.

MiniDisc Mastering at the Pressing Plant

A mastering system for MiniDisc is shown in Fig. 28. The MiniDisc master tape from the studio is also played by on a digital master recorder. The compressed audio signal and subdata information are input into the address generator, which sends data strings of 16-bit information to the compact disc code processor. Address information is converted from cluster/sector time units to CD information, and is input into the compact disc code processor, wherein both audio and subdata signals are processed into CD format signals for input into the mastering machine. This completes the production of a MiniDisc master disc.

Fig. 27 CD Mastering System

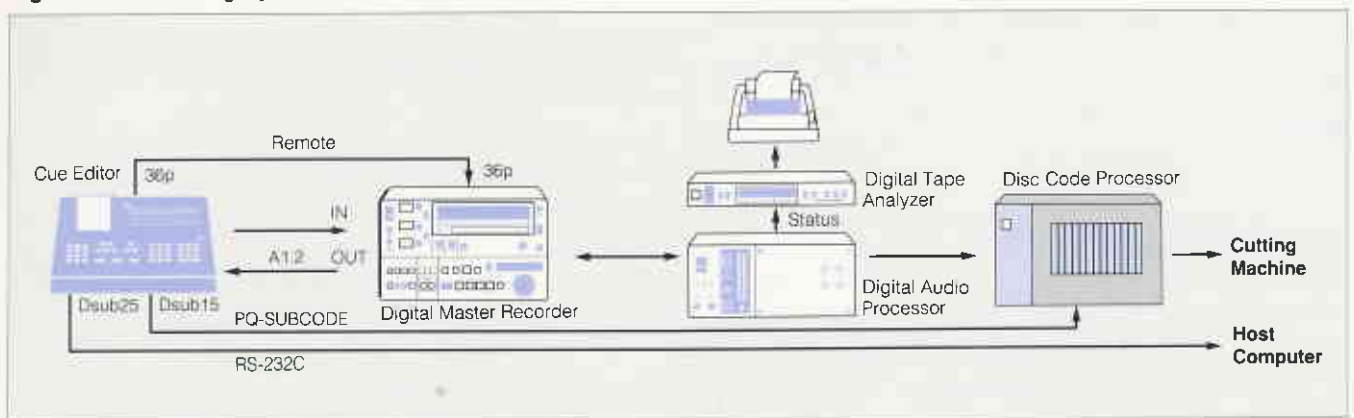
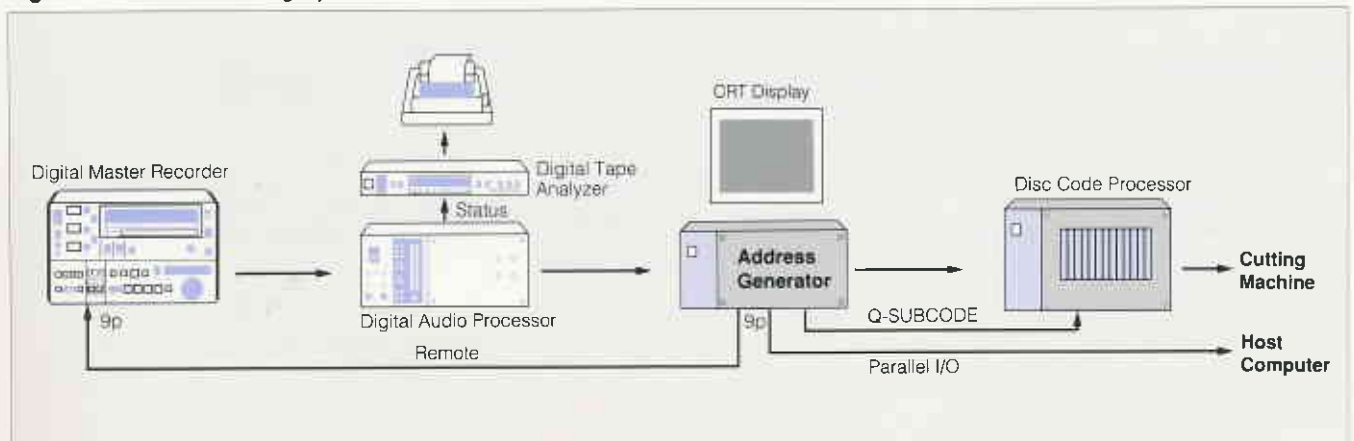

Fig. 28 MiniDisc Mastering System



Glossary of MiniDisc Terminology

A/D Conversion

Analog audio signals are converted into digital signals by dividing them into constant time intervals and converted into amplitudes at various points. These are represented in binary digital code as "1" and "0" pulses.

ADIP - Address In Pre-groove

Addresses are formatted at fixed time intervals on a recordable MiniDisc which has been stamped with grooves that have been formed in a slightly meandering pattern created by a sine wave signal under constant linear velocity control.

ATRAC - Adaptive Transform Acoustic Coding

The digital data compressing system developed for MiniDisc in which audio signals can be reproduced with only about 1/5th in the data normally required for high fidelity reproduction.

CD-MO — CD Magneto-Optical

A recordable magneto-optical version of CD.

CD-ROM — CD Read-Only Memory

A CD recorded with programs and data for computer applications.

CIRC — Cross Interleave Reed-Solomon Code

An error correction method combining the Reed-Solomon code, which is an error correction code with a high random error correction capability, with an interleave method to convert burst errors into random errors.

Cluster

A minimum recording unit in MiniDisc. One cluster = 36 sectors.

CLV — Constant Linear Velocity

A pickup must be moved along a track on a disc at a constant linear velocity (CLV) in order to pick up the same amount of data within a unit of time. CLV in the disc/pickup relationship is maintained by gradually varying disc speed according to pickup location on the disc. The disc rotates the slowest at the outer circumference (where the distance covered by the pickup in one disc revolution is greatest), and the fastest in the inner circumference (where the distance covered by the pickup in one revolution is shortest).

Curie Temperature

The temperature at which magnetism of a specific material dissipates. This temperature varies according to the material.

D/A Conversion

Conversion of digital "1" and "0" signals into analog signals.

Decoder

A device used to restore processed (encoded) signals back to their original form.

DRAM — Dynamic Random Access Memory

A semiconductor device which can store "1" and "0" digital data in a series of capacitors. The MiniDisc format uses DRAMs to store signals.

EFM — Eight to Fourteen Modulation

The modulation system used to convert 8-bit encoded signals into 14-bit signals to match digital signals to disc transmission characteristics.

Encoder

A device used to process (encode) signals into a specific form.

Interleave

Conversion to rearrange digital signals under a certain protocol to improve error correction capability.

kA/m (Oe)

Kiloampere/meter (Oersted). Measurement units for expressing magnetic strength.

Kerr Effect

A phenomenon in which the polarization plane of laser light reflected from a material shifts in one of two directions depending upon its "plus" or "minus" magnetic polarization.

Lead-in Area

The area on a disc before the program area, starting at an inside diameter of 29 mm, in which table of contents (TOC) data is recorded.

Lead-out Area

The area on a disc outside the program area where music signals are not recorded.

Link Sector

Found only in recordable MiniDiscs, this sector links the beginning and end of a recording. There are three link sectors in one cluster.

Magnetic Field Modulation

The high-speed modulation of a magnetic field in magneto-optical recording to represent an input signal by magnetic orientation.

Magneto-Optical Layer

A thin layer within a recordable MiniDisc on which "1" and "0" signals can be recorded by the reversal of magnetic orientation.

Masking Effect

A psychoacoustic phenomenon in which certain sounds are rendered inaudible by higher-level sounds on adjacent frequencies.

Mbit

Megabit. Unit to express digital data volume. One million bits.

MDCT — Modified Discrete Cosine Transform

A technique to convert time-domain signals into spectral signals for each fixed time block. MDCT assures highly efficient coding with little connection distortion between blocks because conversion is performed using a special window function for overlapped halves between adjacent blocks.

micron

One-millionth of a meter.

ms

Millisecond. One thousandth of a second.

m/s

Meters per second. Unit to express velocity.

mW

Milliwatt. Unit to express electrical current. One thousandth of a Watt.

Nanosecond

An increment of time. One billionth of a second.

Oersted

A measurement unit for expressing magnetic strength. Abbreviated as Oe.

Overwrite

The practice of writing new data over existing unerasured data.

Photodiode

A device which converts light into electrical signals at levels proportional to the quantity of light.

Pit

A hole of fixed width and depth, but of 0.9microns or longer, formed directly under the reflective layer of an optical disc. The presence or absence of a pit in a tracking line determines the "1" or "0" signals in digital recording.

Polarization Beam Splitter

A prism that distributes light in accordance with its polarization orientation.

Polycarbonate

An engineering plastic used to form substrates for optical and magneto-optical discs.

Pre-groove

A groove molded into recordable MiniDiscs which assists in tracking control. The pre-groove is meandered in a certain pattern in order to create addresses throughout the entire disc.

Program Area

The area on the disc for the recording of audio programs.

Psychoacoustics

The study of human hearing.

Sampling Frequency

The number of divisions on an audio signal made in one second when digitizing an analog signal.

SCMS — Serial Copy Management System

A system developed to limit digital dubbing to first generation copies only. Digital dubbing from a copy is not possible. Although not a MD format specification, SCMS is expected to be implemented in all MiniDisc products with recording capability.

Sector

A unit of data specified for CD-ROM discs, and also used for MiniDiscs. One sector is 2352 bytes.

Skew (Tilt) Angle

The amount of variation of a disc from its intended plane of orientation.

Sound Group

Compressed data of 424 bytes obtained by encoding two channels of audio data 11.6 ms in duration.

Spacial Frequency

Expressed in lines per millimeter, it is how finely an optical pickup can read data. It is one factor in expressing frequency characteristics.

Stamper

The recording master disc cut with pits, grooves, and addresses. It is used to reproduce substrates of optical and magneto-optical discs.

TOC — Table Of Contents

The generic term for all subdata (track number, playing time, etc.) apart from the audio data.

UTOC — User Table Of Contents

Found only on recordable MiniDiscs, this area contains subdata (track number, etc.) which can be rewritten by the user.

Wow and Flutter

Frequency fluctuation due to inconsistent speed in recording and playback. Slow fluctuation is called "wow," and rapid fluctuation is called "flutter."

